

Matter with Electromagnetic Resonance

HAL presentation

By Tim Waterman © 11/2015

A more detailed description can be found in

“Matter with Electromagnetic Resonance”

Print ISBN:978-0-9907392-7-2

Published by Maple Creek Media

Also available from Amazon and Barnes and Noble

Contact: twater1@comcast.net

Matter with Electromagnetic Resonance

- **Introduction** (*Particles are Resonant Electromagnetic Waves Trapped in Compressed Space*)
- **Spin modes and Compressive modes** [*Visible Matter*]
- **Bounce Modes** [*Dark Matter/Dark Energy*]
- **What do atoms look like?**
- **Unification of Gravity, Electrostatic, Weak, and Strong Forces**
- **The Nature of Galaxies**
- **Supermassive Black Holes and the Neutrino**
- **The Aether**

Introduction to Matter as Compressed Space (the Aether)

- Voltage as a pressure has the ability to compress space (the Aether)
- Matter comprises Electromagnetic waves contained in self-sustaining spherical resonant cavities.
- The containment mechanism is “Snell’s Law” as it pertains to the total internal reflection of Electromagnetic waves at the boundary between two media with different indices of refraction (η).
- η is the relative measure of the speed of light in a material where ($\eta = 1.0$) is defined as the index of refraction in “free space”.
- η is also the relative density of space.

Snell's Law and Critical Angle for total internal reflection (The Containment Mechanism)

$$\theta_2 = \theta_3$$

$$\frac{\sin \theta_1}{\eta_2} = \frac{\sin \theta_2}{\eta_1}$$

$$\theta_1 = 90 \text{ deg}$$

$$\sin \theta_1 = 1$$

$$\theta_2 = \theta_c = \arcsin\left(\frac{1}{\eta_2}\right)$$

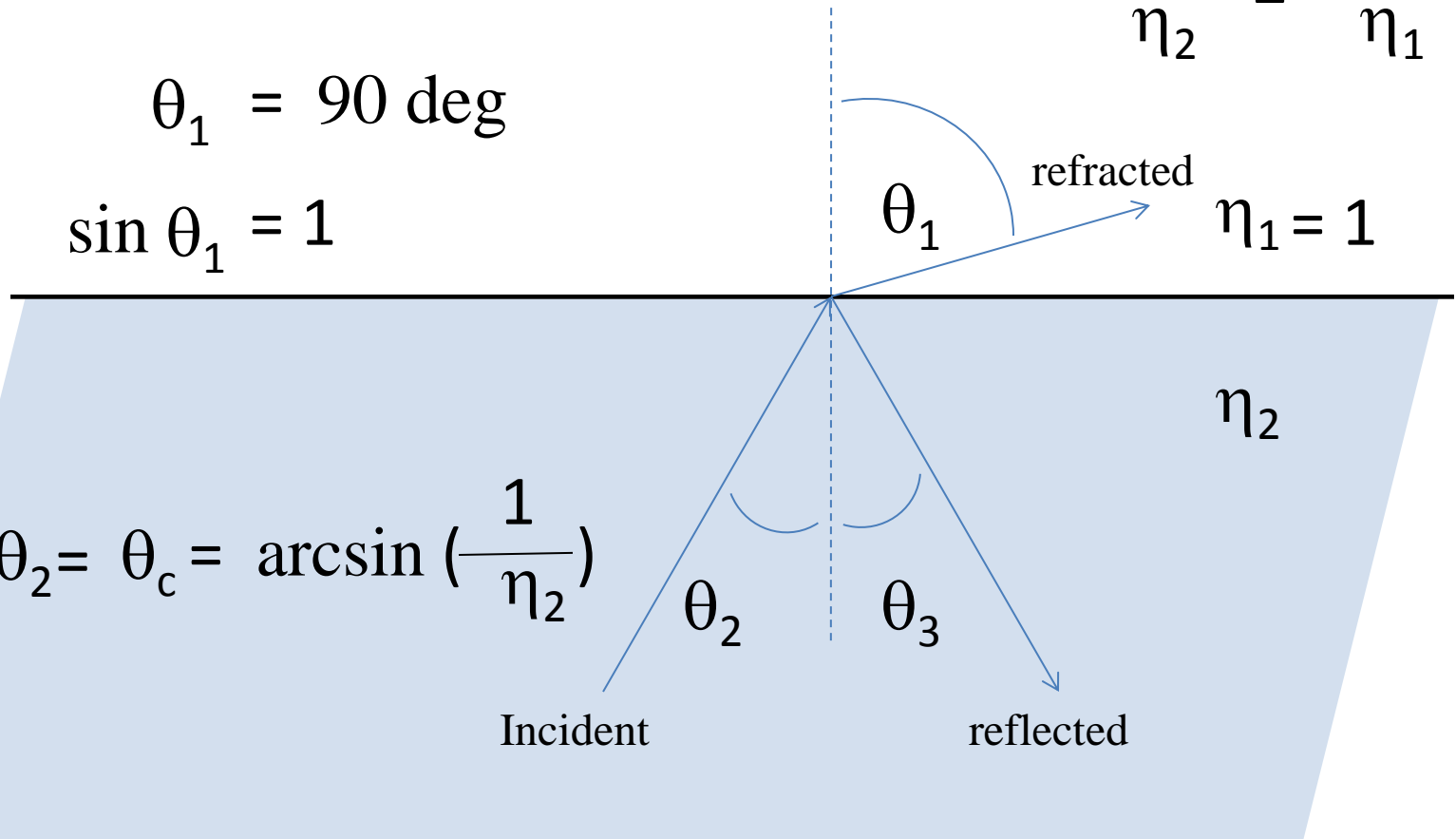

Containment leads to Stable Spherical Resonances

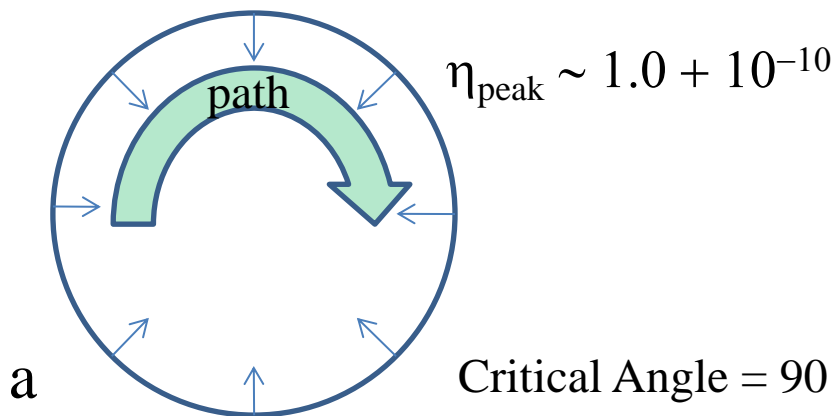

Critical Angle = 90 degrees (Grazing)

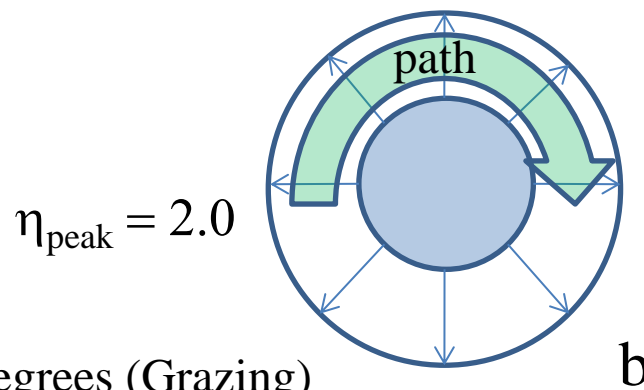

Spin mode - Lowest order mode

Spin mode - 2 tiered mode

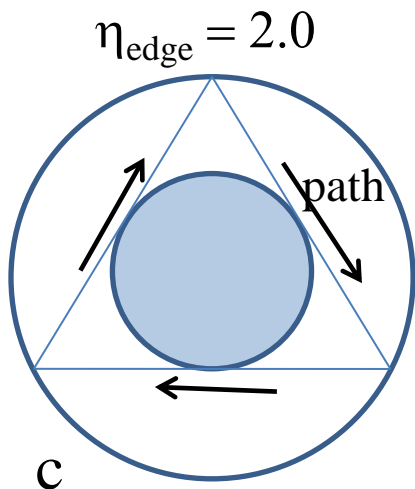

Bounce mode
sides = 3
(unstable)

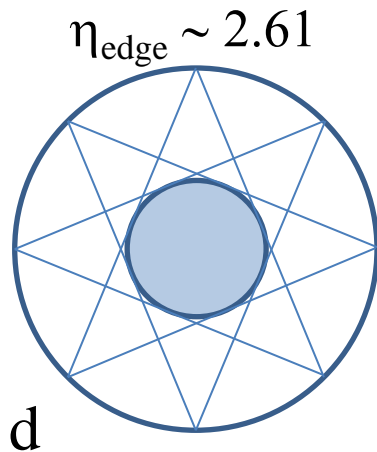

Bounce mode
sides = 8
(unstable)

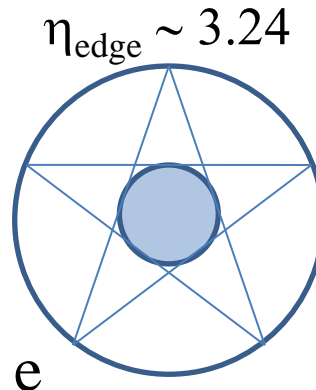

Bounce mode
sides = 5
(stable)

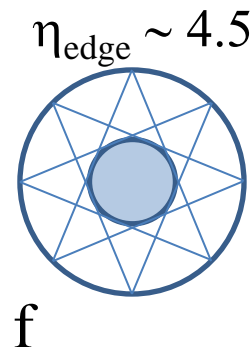

Higher Frequency Bounce Modes
particles ~ 10 even and 10 odd
(stable)

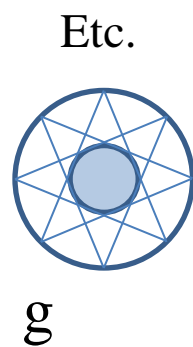

Etc.

Particles were Manufactured in the “Big Bang”

- The “Big Bang” was an impulse function (in time)
- The Fourier transform of an impulse in the time domain is equal amplitude in the frequency domain (**this means equal mass for each kind of particle**)
- In the rapidly expanding unstable Aether, as the peak density drops, excess density bubbles form spontaneously (think shaking a can of soda)
- Since all frequencies are available, when an expanding density bubble’s size reaches a resonant frequency that can become stable, the bubble precipitates out as matter.
- More massive particles (Dark Matter) precipitate out first.

Resonant Path Through the Particle (*density bubble*) dictates allowable Polarization and the volume of

charge Q

Electron / Proton / Neutron / Neutrino

Dark Matter / (*and unstable Dark Energy*)

(Radial Polarization)

(Circumferential Polarization)

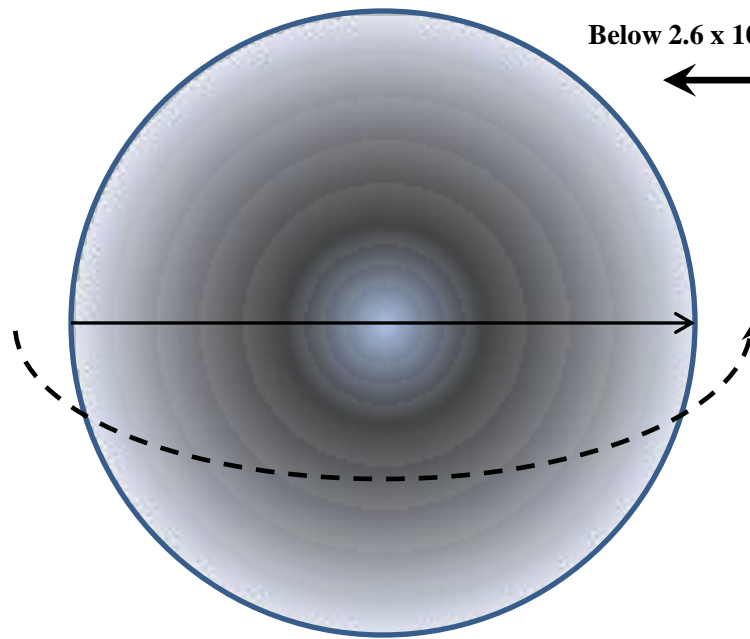

Below 2.6×10^{23} Hz

Above 2.6×10^{23} Hz

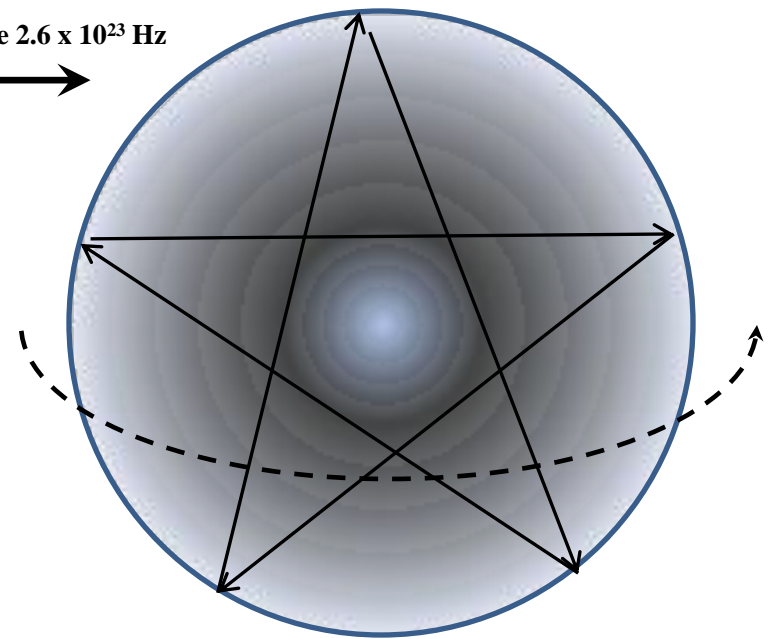

Visible Matter (at conception) has a path length through the center equal to the path length around with a peak “Space Density” of $[\eta_{\text{peak}} = (\pi - 1)]$

This determines the volume of charge Q

Dark Matter has a path length near the center equal to the path length around but this polarization is not supported with a path through the center (critical angle > 0.0 degrees)

Some of the surprising possibilities, explanations and ramifications of this theory include:

- All stable particles are spherical bubbles with different wall thicknesses, peak densities, masses, energies and resonant frequencies
- The actual size and shape of electrons, protons and neutrons can be predicted
- Explains what the likely “quarks” are in a proton
- Predicts the existence of Dark Matter/Dark Energy, its size shape and other properties
- Explains why anti-matter is less stable than matter
- Explains why the speed of light is constant and has hit its maximum speed today
- Possible explanation for Supernovas “Dark Neutrons”
- Explains what neutrinos are and their properties
- Provides a simple mechanism that explains how atoms are put together
- Allows a simple understanding of what gravity is
- Unifies the four known forces [gravity, nuclear strong, nuclear weak, electrostatic]
- Explains where galaxies come from
- Explains supermassive black holes

Visible Matter

Spin Modes (Radial Polarization)

Mechanism for spinning charge (Changing Density and Virtual Ground)

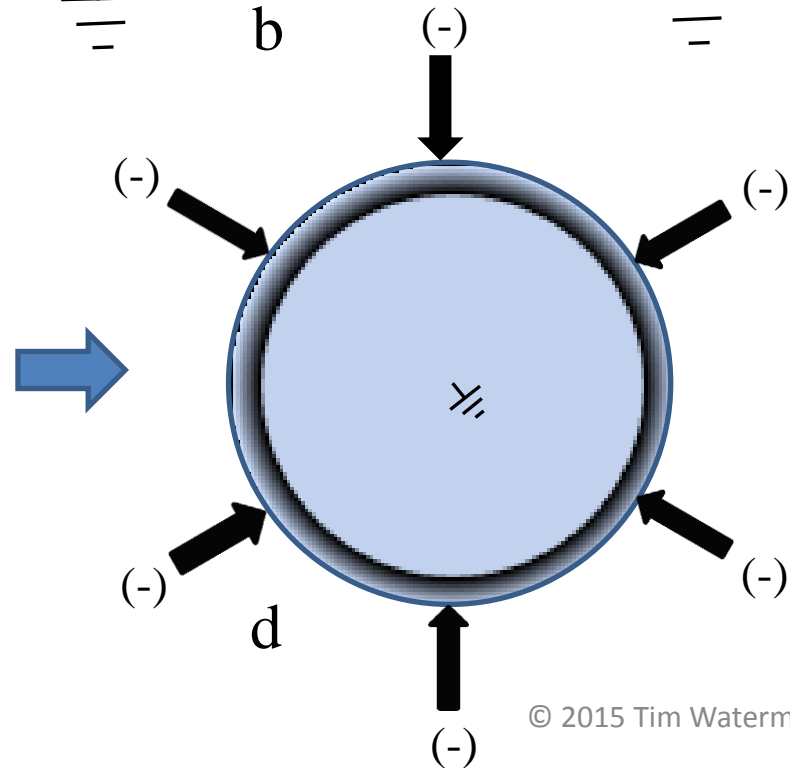
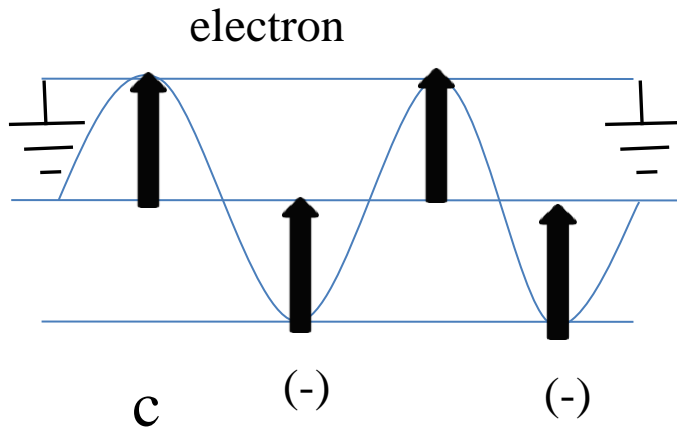
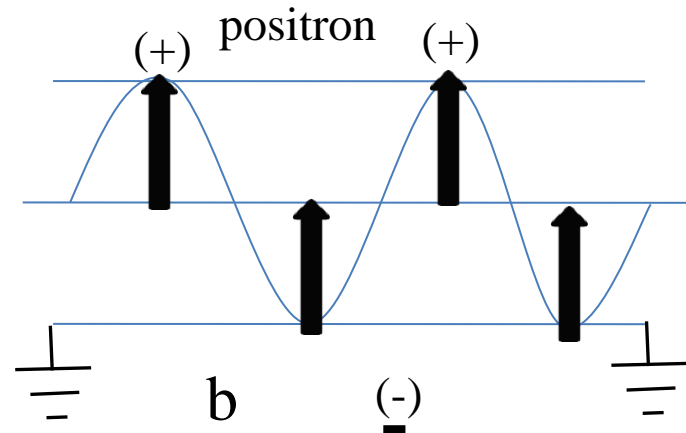
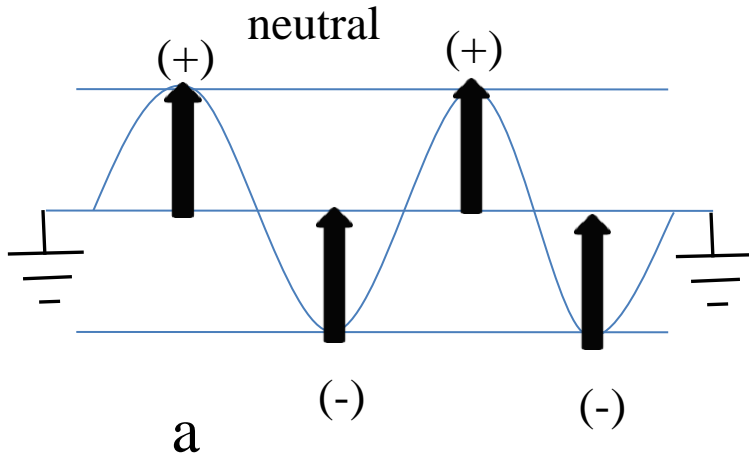

A “Visible” Resonant Bubble (1.0 Q) is formed at the instant that the path length through the center of the expanding density bubble is equal to the path length around the circumference

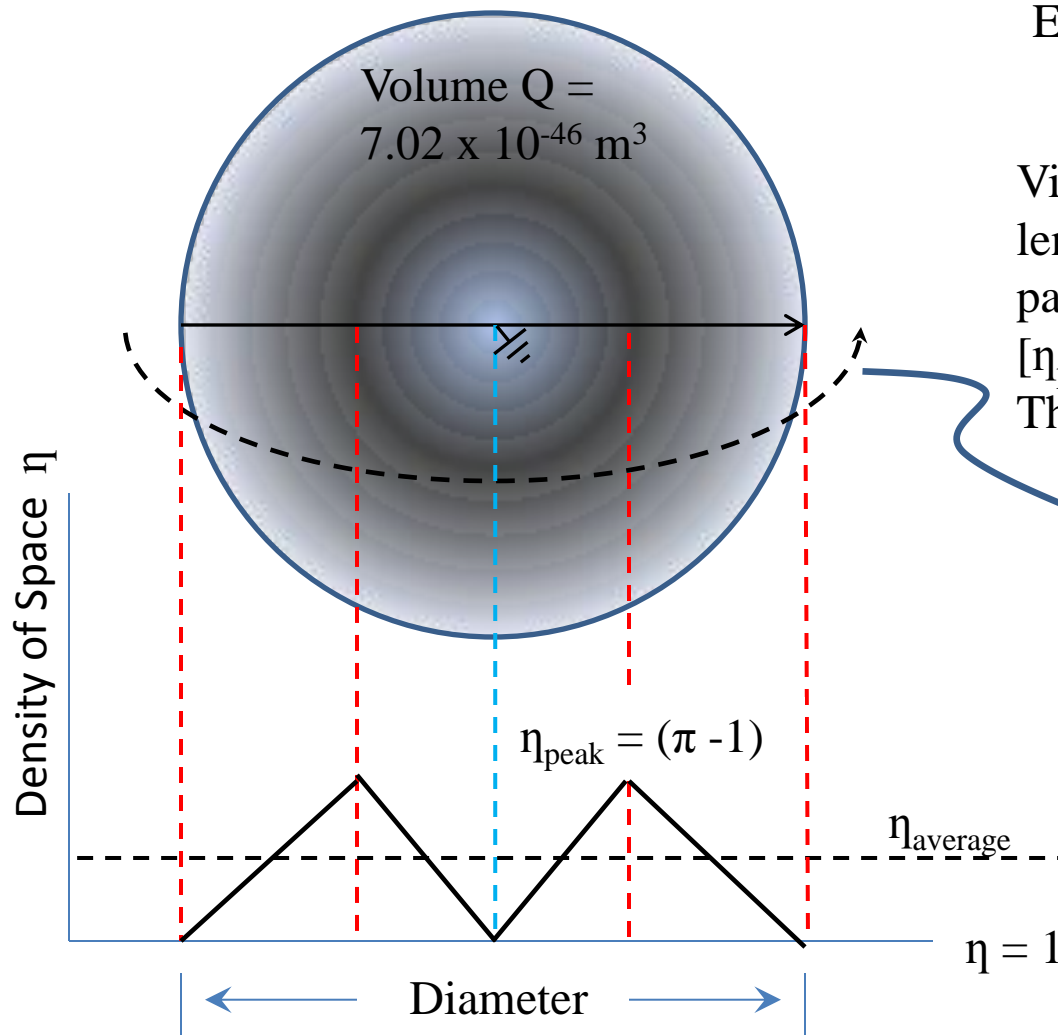

Electron / Proton / Neutron / Neutrino
(Radial Polarization)

Visible Matter (at conception) has a path length through the center equal to the path length around @ $2.509 \times 10^{23} \text{ Hz}$
 $[\eta_{\text{peak}} = (\pi - 1)]$
 This determines the volume of charge Q

$$\pi/2 \cdot \text{Diameter} = \text{path length Around circumference}$$

$$\begin{aligned} \eta_{\text{average}} &= (1 + \eta_{\text{peak}})/2 \\ &= (1 + (\pi - 1))/2 \\ &= \pi/2 \end{aligned}$$

$$\pi/2 \cdot \text{Diameter} = \text{path length Through center}$$

Spherical Resonances Visible Matter

The resonant volume of Q (7.02×10^{-46} meters³) forms at 2.509×10^{23} Hz. It is not stable at that frequency. The fixed volume keeps expanding (constant charge / lower charge density).

There are two stable “spin resonant” modes and one stable “non-spin” mode. The more complex Proton/Neutron forms first with the pressure pointing outward. The electron forms with the pressure pointing inward and has peak space density only slightly greater than 1.0

The non-spinning compressive wave Neutrino (not shown) forms when the expanding bubble wall thickness hits the Planck length $\sim 1.6 \times 10^{-35}$ meters

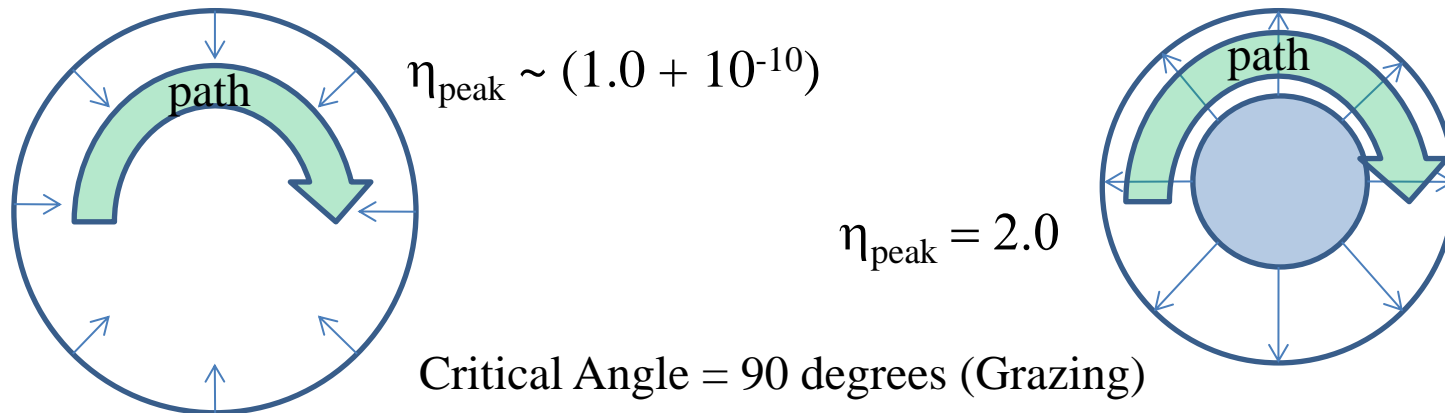

Smooth Rotation Lowest order mode
(Electron)

Smooth Rotation 2 tiered mode
(Proton / Neutron)

The Electron

A virtual ground forms
in the center

Like charges on
opposite sides repel

This makes a thin shell
structure

Inner circumference
rotates at the speed of
light divided by the
density " C/η "

Outer circumference
rotates at the speed of
light " C "

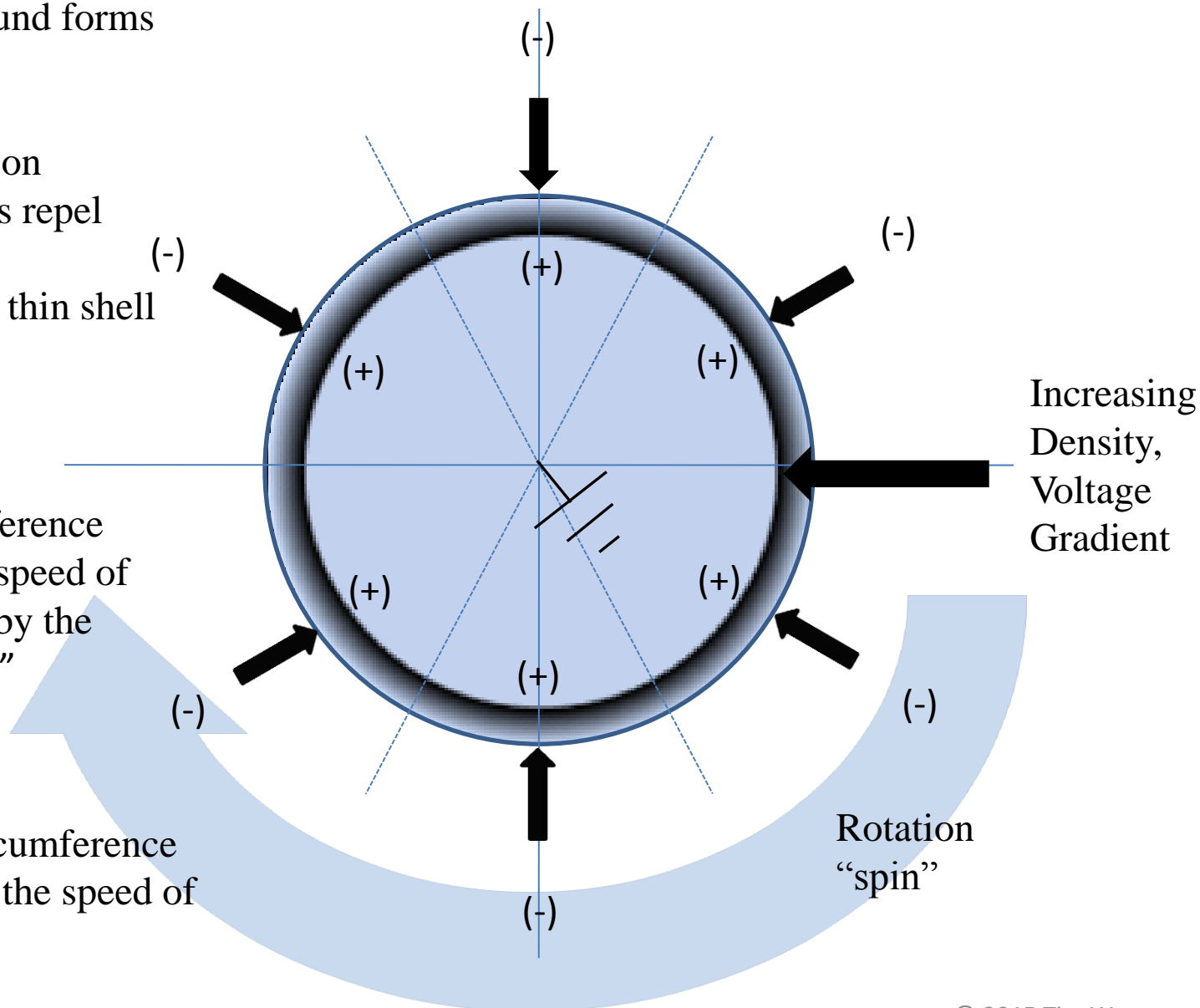

2 Tiered Resonant Particle

8 equal size charge
volumes 4 (+) 4 (-)

The Neutron

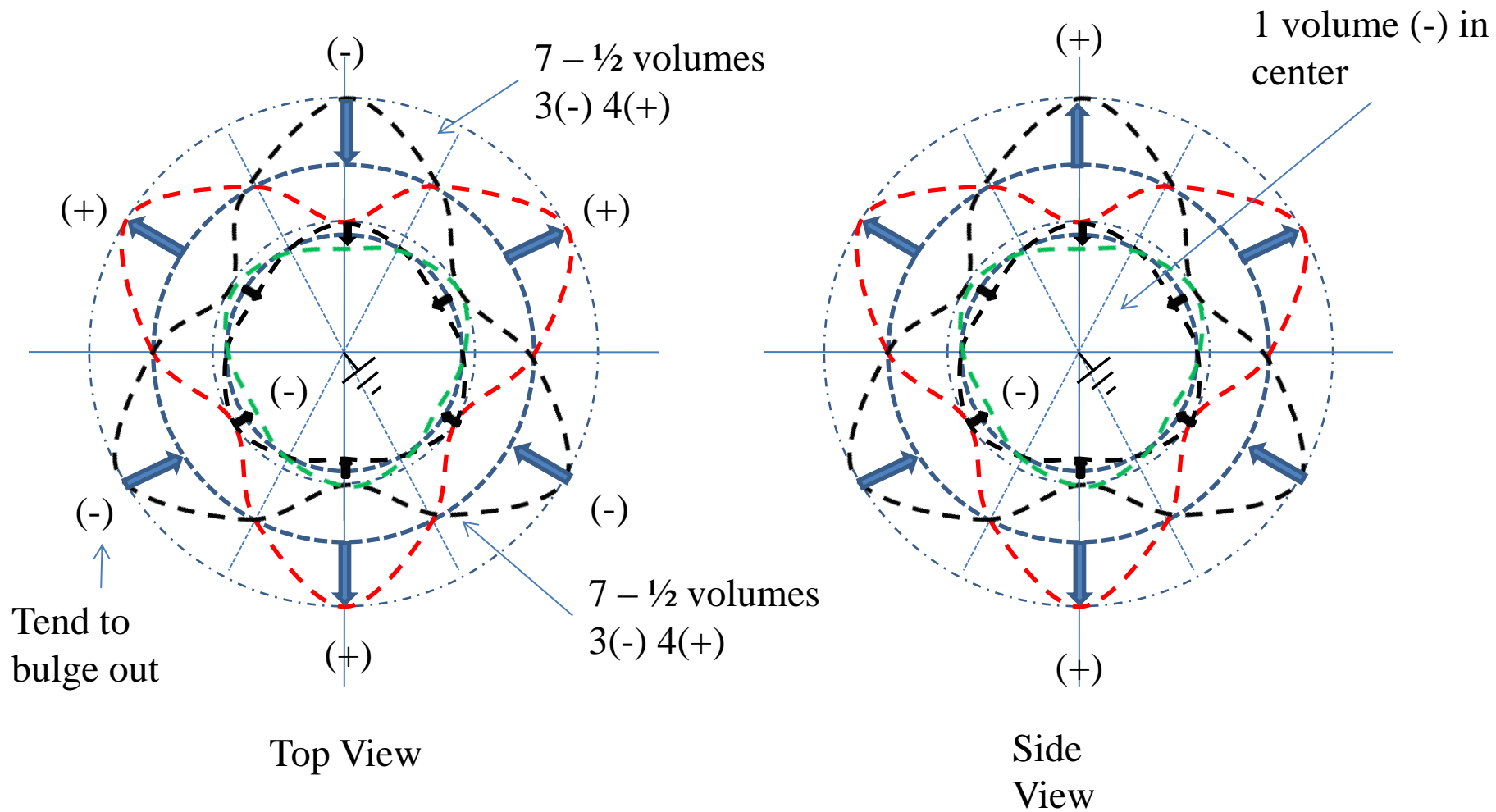

Derived Equations (spin modes / visible matter)

Relative Density of Space “ η ”

Relative Mass and Frequency

$$\text{Mass}_1 = Q_1^2 \cdot \eta_1^{10} \cdot \text{Mass}_0 \quad \text{where } \text{Mass}_0 = 9.1 \times 10^{-31} \text{ kg (electron mass)}$$

Because of the relationship between mass-energy and resonant frequency-energy

$$\text{Freq}_1 = Q_1^2 \cdot \eta_1^{10} \cdot \text{Freq}_0 \quad \text{where } \text{Freq}_0 = 1.236 \times 10^{20} \text{ Hz (electron frequency)}$$

Where

- Mass_1 = Peak mass for new particle #1
- Q_1 = Peak amount of space being compressed in particle #1
- η_1 = Peak index of refraction of that compressed space
- Freq_1 = Resonant frequency for new particle #1

Equation relating the relative Density of Space “ η ” to relative Resonant Frequency

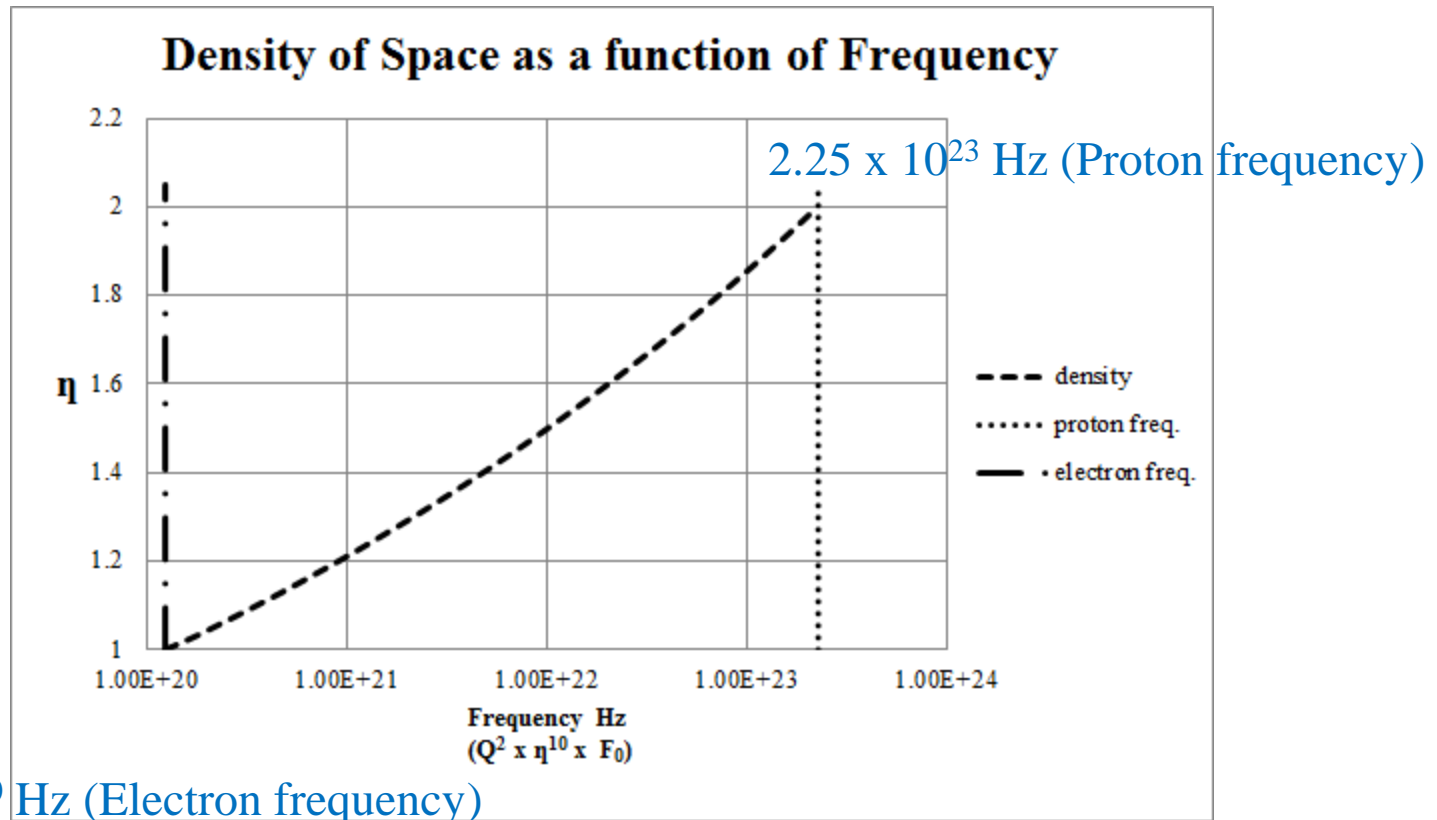

Q (compressed volume) has been allowed to vary from 1.0 (electron) to 1.333 (proton)

Dark Matter / Dark Energy

Bounce Modes
(Circumferential Polarization)

Spherical Resonances Dark Matter / Dark Energy

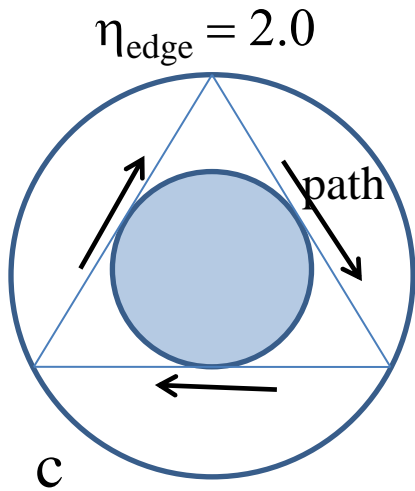

c

Bounce mode
sides = 3
(unstable)

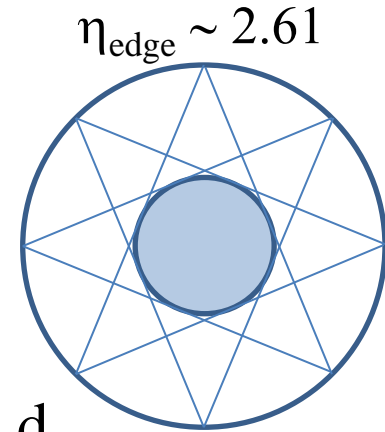

d

Bounce mode
sides = 8
(unstable)

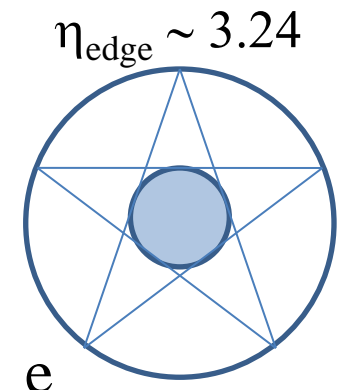

e

Bounce mode
sides = 5
(stable)

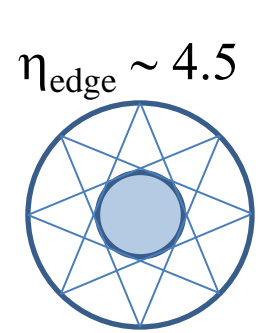

f

Higher Frequency Bounce Modes
particles ~ 10 even and 10 odd
(stable)

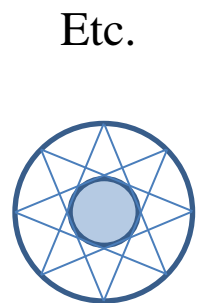

g

Etc.

Total Internal Reflection at Specific Critical Angles

A “Dark” Resonant Bubble (1.0 Q) is formed at the instant that the path length near the center of the expanding density bubble is equal to the path length around the circumference

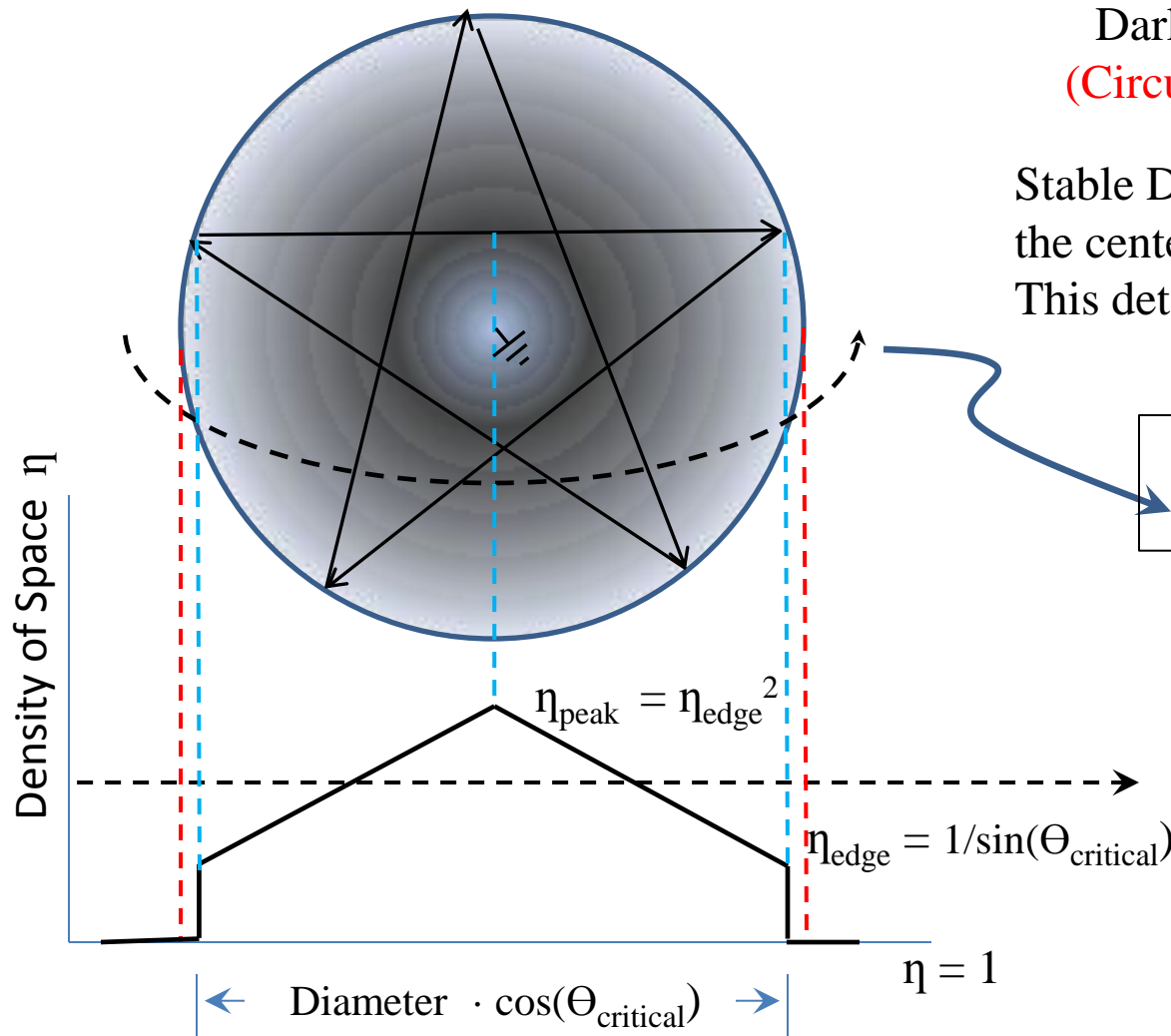

Dark Matter / Dark Energy
(Circumferential Polarization)

Stable Dark Matter has a path length near the center equal to the path length around. This determines the volume of charge Q

$$\eta_{\text{edge}} \cdot \pi/2 \cdot \text{Diameter} = \text{path length Around circumference}$$

$$\eta_{\text{average}} = (\eta_{\text{edge}} + \eta_{\text{peak}})/2$$

$$\eta_{\text{average}} = \eta_{\text{edge}} \cdot (1 + \eta_{\text{edge}})/2$$

Only specific Space Densities can form Stable Particles (~20)

5 – Sided Bounce Path (First Stable Dark Matter Particle)

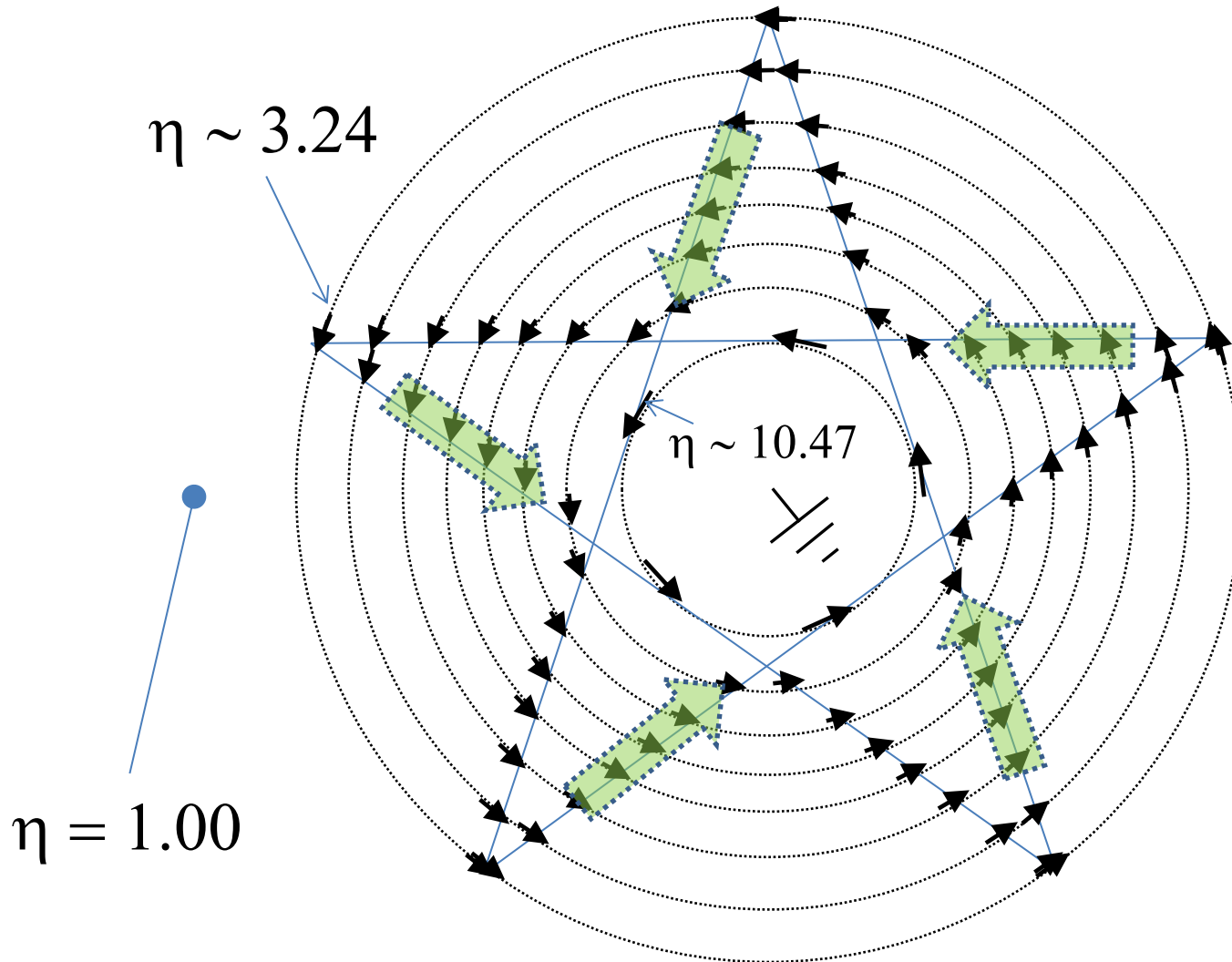

Top View of “Bounce Mode” Dark Matter

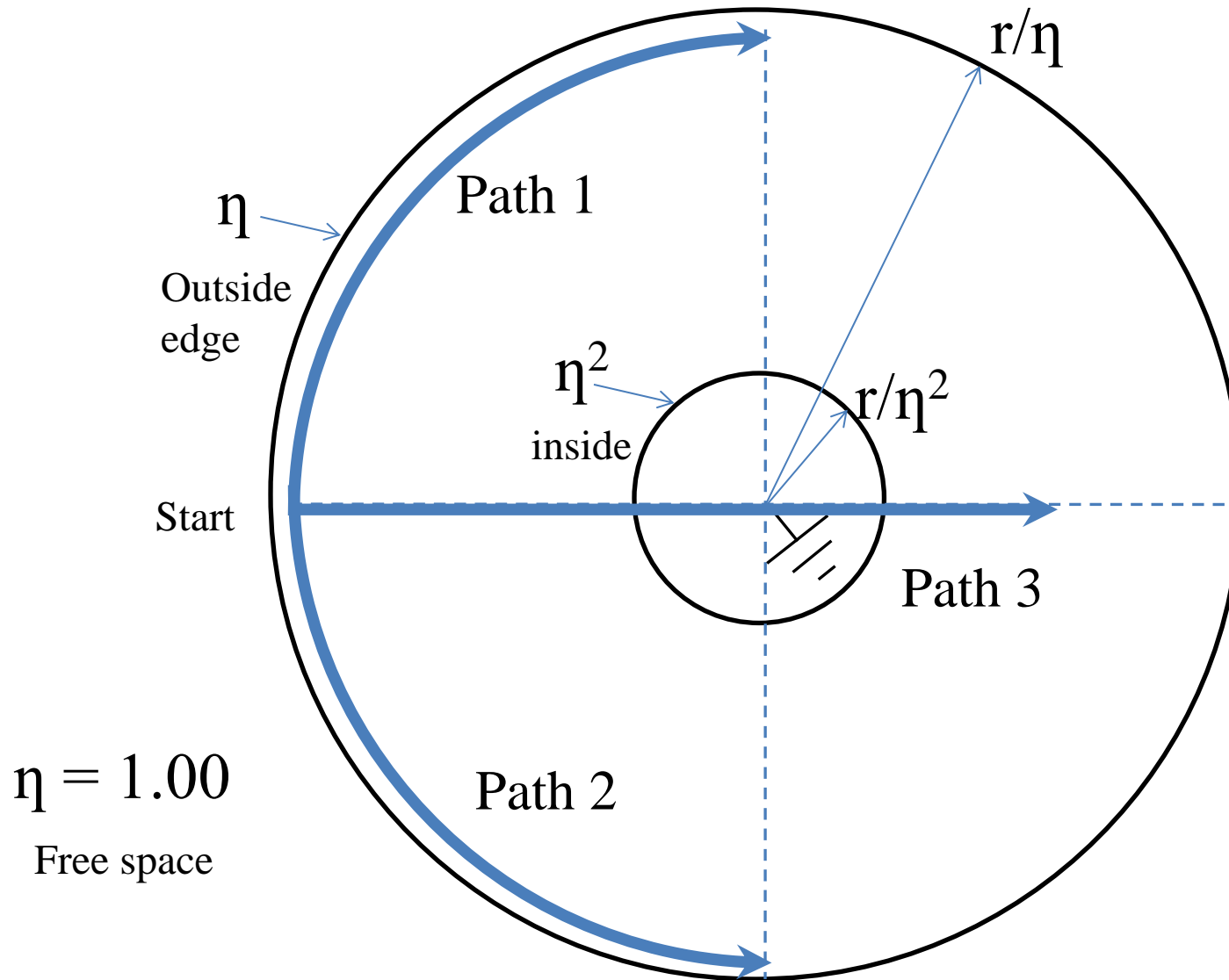

For Bounce Modes the maximum density η^2 Occurs at the minimum radius of r/η^2

Recombine in phase

Density Profile of Dark Matter

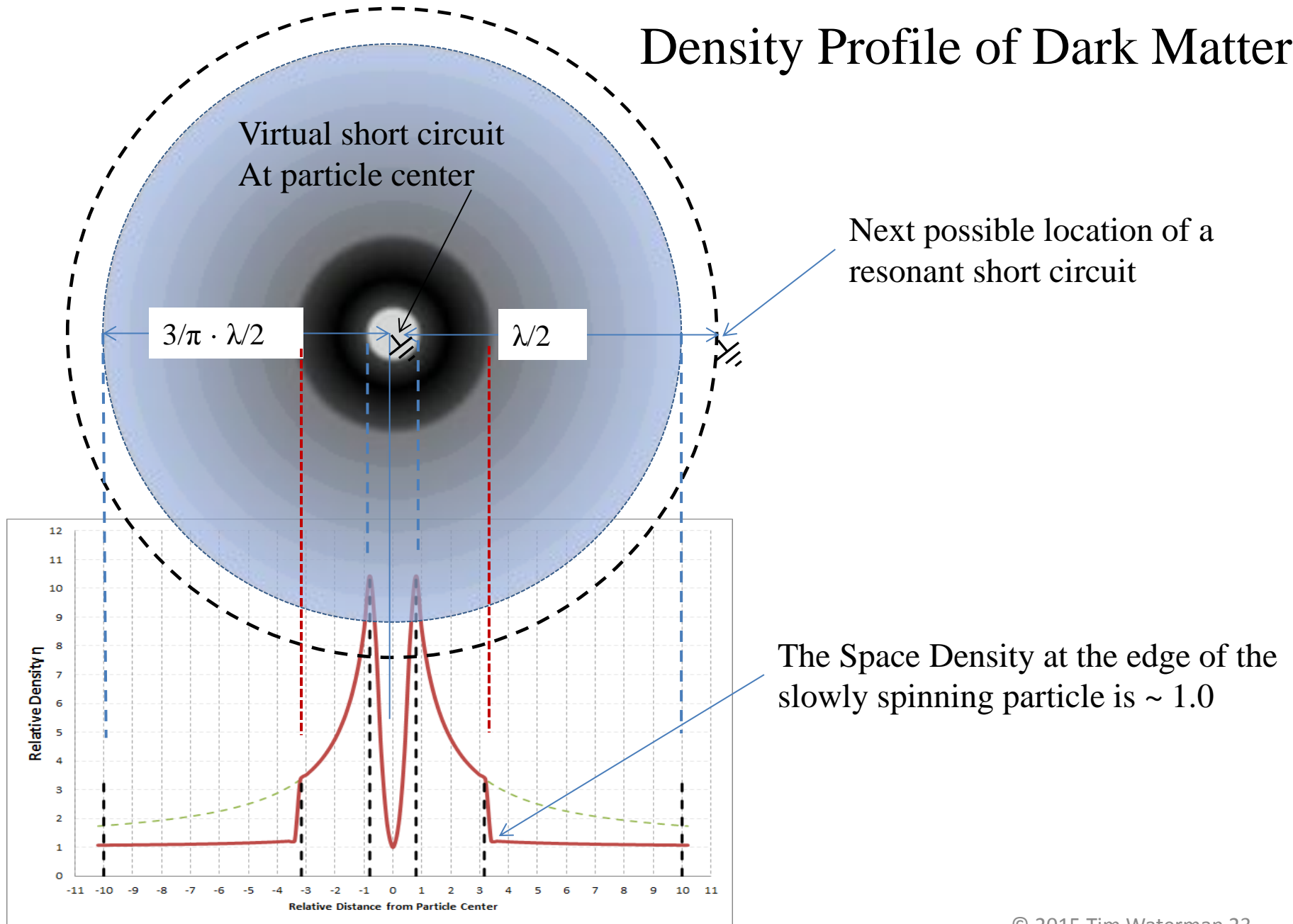

Derived Equations (bounce modes / dark matter)

Relative Density of Space “ η ”

Relative Mass and Frequency

$$\text{Mass}_1 = Q_1^2 \cdot \eta_1^{13} \cdot \text{Mass}_0 \quad \text{where } \text{Mass}_0 = 9.1 \times 10^{-31} \text{ kg (electron mass)}$$

Because of the relationship between mass-energy and resonant frequency-energy

$$\text{Freq}_1 = Q_1^2 \cdot \eta_1^{13} \cdot \text{Freq}_0 \quad \text{where } \text{Freq}_0 = 1.236 \times 10^{20} \text{ Hz (electron frequency)}$$

Where

- Mass_1 = Peak mass for new particle #1
- Q_1 = Peak amount of space being compressed in particle #1
- η_1 = Peak index of refraction of that compressed space
- Freq_1 = Resonant frequency for new particle #1

Dark Matter

~ 20 Stable Resonances (out of ~ 70)

| # | Index of refraction η (space density) | # sides | critical angle (deg) | Resonant Frequency (Hz) | Wavelength (meters) | outside diameter (meters) | effective inside diameter (meters) | mass (kg) |
|----|---|---------|----------------------|-------------------------------|------------------------|------------------------------|---------------------------------------|-----------|
| 1 | 3.236 | 5 | 18.00 | 5.28E+26 | 5.69E-19 | 1.68E-19 | 5.19E-20 | 3.88E-24 |
| 2 | 11.474 | 36 | 5.00 | 7.38E+33 | 4.06E-26 | 3.38E-27 | 2.95E-28 | 5.43E-17 |
| 3 | 15.290 | 48 | 3.75 | 3.08E+35 | 9.72E-28 | 6.07E-29 | 3.97E-30 | 2.27E-15 |
| 4 | 19.107 | 60 | 3.00 | 5.59E+36 | 5.36E-29 | 2.68E-30 | 1.40E-31 | 4.12E-14 |
| 5 | 19.744 | 31 | 2.90 | 8.56E+36 | 3.50E-29 | 1.69E-30 | 8.58E-32 | 6.30E-14 |
| 6 | 23.562 | 37 | 2.43 | 8.53E+37 | 3.52E-30 | 1.43E-31 | 6.05E-33 | 6.28E-13 |
| 7 | 27.381 | 43 | 2.09 | 6.01E+38 | 4.99E-31 | 1.74E-32 | 6.36E-34 | 4.42E-12 |
| 8 | 28.017 | 88 | 2.05 | 8.10E+38 | 3.70E-31 | 1.26E-32 | 4.51E-34 | 5.96E-12 |
| 9 | 31.200 | 49 | 1.84 | 3.28E+39 | 9.14E-32 | 2.80E-33 | 8.97E-35 | 2.42E-11 |
| 10 | 31.836 | 100 | 1.80 | 4.27E+39 | 7.03E-32 | 2.11E-33 | 6.63E-35 | 3.14E-11 |
| 11 | 32.473 | 51 | 1.76 | 5.52E+39 | 5.44E-32 | 1.60E-33 | 4.92E-35 | 4.06E-11 |
| 12 | 35.019 | 55 | 1.64 | 1.47E+40 | 2.04E-32 | 5.56E-34 | 1.59E-35 | 1.08E-10 |
| 13 | 35.655 | 112 | 1.61 | 1.86E+40 | 1.61E-32 | 4.32E-34 | 1.21E-35 | 1.37E-10 |
| 14 | 36.292 | 57 | 1.58 | 2.34E+40 | 1.28E-32 | 3.37E-34 | 9.29E-36 | 1.72E-10 |
| 15 | 39.475 | 124 | 1.45 | 6.98E+40 | 4.30E-33 | 1.04E-34 | 2.63E-36 | 5.14E-10 |
| 16 | 40.111 | 63 | 1.43 | 8.60E+40 | 3.49E-33 | 8.31E-35 | 2.07E-36 | 6.33E-10 |
| 17 | 40.748 | 128 | 1.41 | 1.06E+41 | 2.84E-33 | 6.66E-35 | 1.64E-36 | 7.77E-10 |
| 18 | 43.294 | 136 | 1.32 | 2.32E+41 | 1.29E-33 | 2.85E-35 | 6.59E-37 | 1.71E-09 |
| 19 | 43.931 | 69 | 1.30 | 2.81E+41 | 1.07E-33 | 2.32E-35 | 5.29E-37 | 2.07E-09 |
| 20 | 44.567 | 140 | 1.29 | 3.38E+41 | 8.87E-34 | 1.90E-35 | 4.26E-37 | 2.49E-09 |

Measured Data from the Galaxy and beyond

Support this Resonant Theory of Matter

| Particle | η Space Density | Resonant Frequency Hz | Energy electron volts | Relative Mass vs. proton | mass kg | Reference Measured Data to support |
|--|----------------------------|--------------------------|--------------------------|-----------------------------|-----------|---------------------------------------|
| Neutrino | $\eta = 2.25$ | 7.665E+13 | 3.174E-01 | 3.406E-10 | 5.643E-37 | A |
| Electron | $\eta = 1$ | 1.236E+20 | 5.119E+05 | 0.00055 | 9.100E-31 | B |
| Proton | $\eta = 2$ | 2.250E+23 | 9.318E+08 | 1.00000 | 1.657E-27 | C D F |
| Dark Neutron #sides = 3 | $\eta = 2$ | 1.013E+24 | 4.193E+09 | 4.5 | 7.454E-27 | C D F |
| Unstable Higgs or Galactic source #sides = 8 | $\eta = 2.613$ | 3.274E+25 | 1.356E+11 | 145.52 | 2.411E-25 | E F |
| First Stable Dark Matter #sides = 5 | $\eta = 3.236$ | 5.275E+26 | 2.185E+12 | 2344.52 | 3.884E-24 | D F |
| Unstable Dark Matter #sides = 12 | $\eta = 3.864$ | 5.285E+27 | 2.189E+13 | 23489.50 | 3.891E-23 | D F |

References

Table references A, B, C, D, E, F

A. Cosmic Mismatch Hints at the Existence of a "Sterile" Neutrino

Scientific American, February 20, 2014|By [Clara Moskowitz](#)

B. theory.uwinnipeg.ca/mod_tech/node177.html

or **hyperphysics.phy-astr.gsu.edu/hbase/quantum/debrog2.html**

C. [The HAWC Gamma-Ray Observatory: Sensitivity to Steady and Transient Sources of Gamma Rays](#) - [HAWC](#) Collaboration ([Abeysekara, A.U. et al.](#)) arXiv:1310.0071 [astro-ph.HE]

HAWC Sensitivity to Diffuse Emission

Petra Huntemeyer, Hugo Albert Ayala Solares, for the HAWC Collaboration

D. The Vela-X region, (WMAP) data, GeV (Fermi) gamma-ray data, X-ray (ASCA) and TeV gamma-ray (H.E.S.S.) (from [Fermi LAT Collaboration, 2010](#)).

Reference: **[H.E.S.S. observations of the Vela X nebula](#)**, H.E.S.S. Collaboration, F. Dubois et al., Proceedings of the 31st ICRC, Lodz 2009

E. Search for Gamma-ray Spectral Lines with the Fermi Large Area Telescope and Dark Matter Implications

M. Ackermann et al. (23 Sep 2013) arXiv:1305.5597v3 [astro-ph.HE]

F. Study of the Gamma-ray Spectrum from the Galactic Center in view of Multi-TeV Dark Matter Candidates - [Belikov, Alexander V. et al.](#) Phys.Rev. D86 (2012) 083516 arXiv:1207.2412 [astro-ph.HE]

Mass Percentages

Visible / Dark Matter / Dark Energy

New theory Predicts mass percentages consistent with measured data.

There are ~73 potential resonant particle modes

Each particle mode has the same total mass

The lighter the particle, the more there are

- Visible $3/73 = 4.1\%$
- Dark Matter $20/73 = 27.4\%$
- Dark Energy $50/73 = 68.5\%$

Particle Stability determines “Lifetime”

Most of the Unstable Dark Matter Particles
(Dark Energy)
should be disintegrating later, leading to an increasing
expansion rate for the Universe.

Unstable Dark Matter is Dark Energy

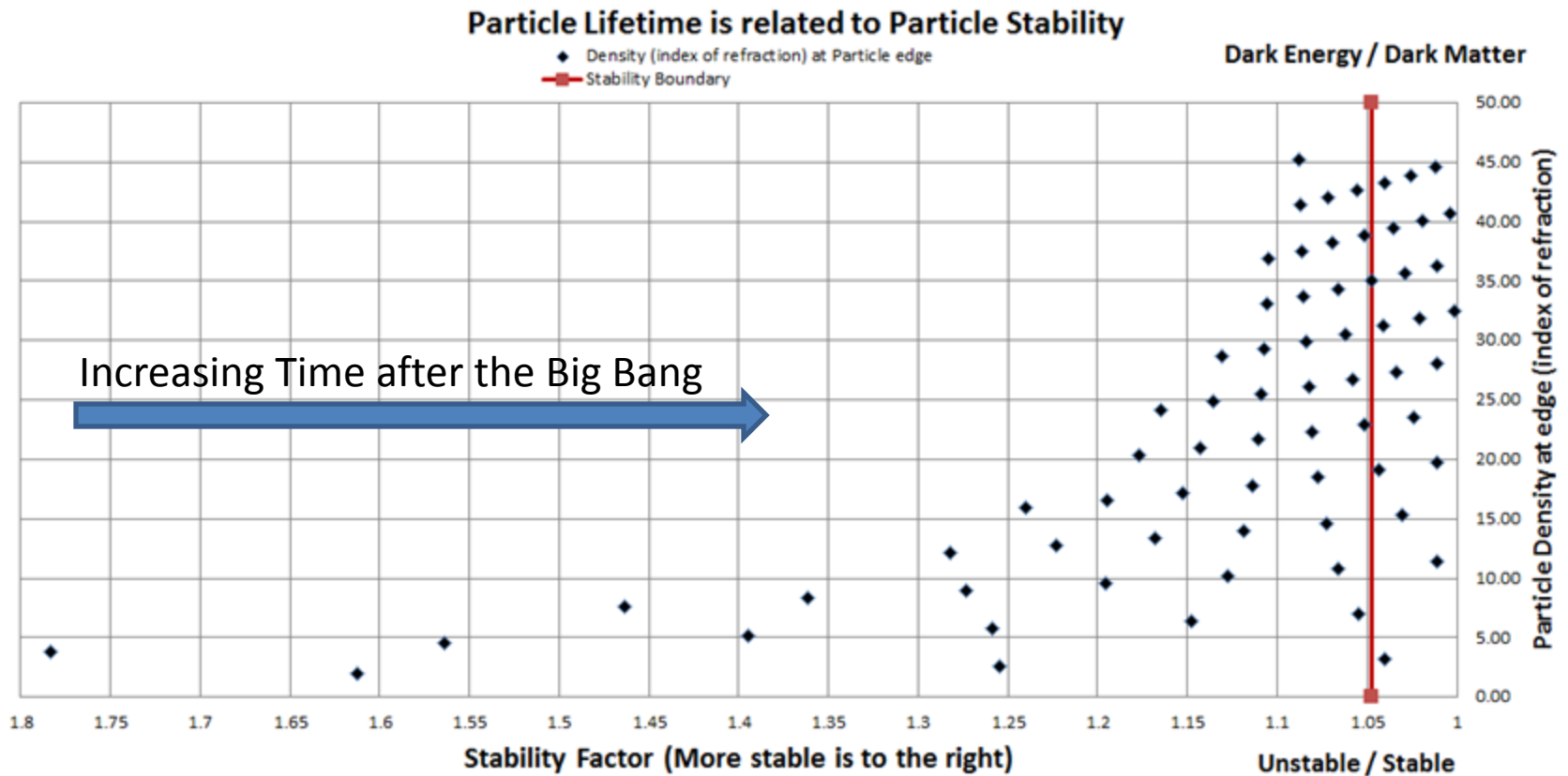

Construct the Atoms

Atoms are not exactly what we thought

- Charged excess density bubbles (electrons, protons and neutrons) fit together in a very specific way.
- Protons and neutrons have oppositely charged regions on their surfaces that allow them to attach together.
- Proton or proton/neutron pairs are small and can penetrate an electron “bubble” that is ~ 1820 times their size.
- The positive charge on the outside of a proton repels the positive charge on the inside of electron...the electron expands.
- The new density relationship allows the calculation of the expanded electron radius
- The spinning nucleus allows the formation of two sets of “electron shells”
- Volume and surface stability dictate the maximum allowable number of electrons in each stable shell

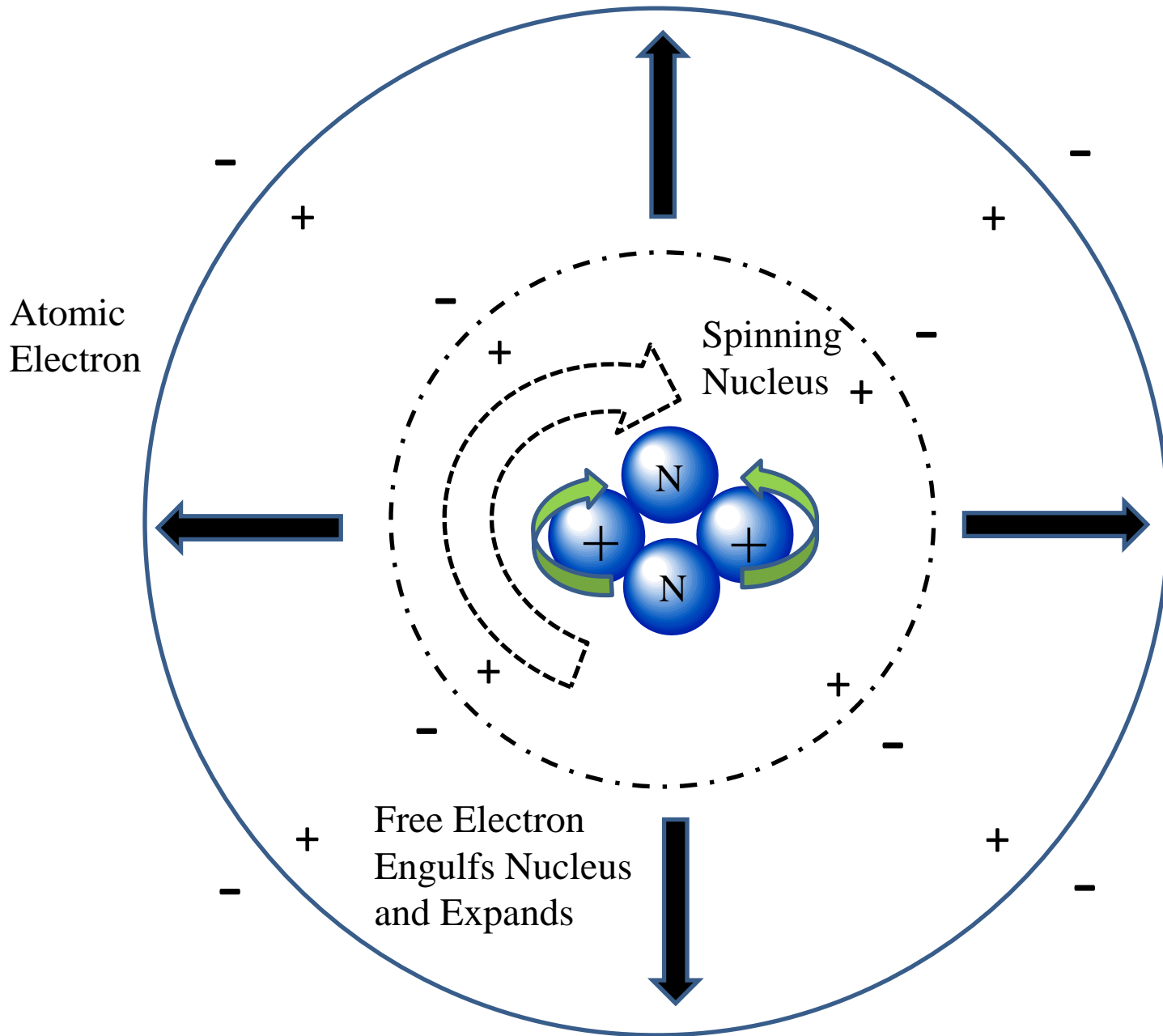

Volume and area constraints along with the spin of the nucleus dictate where stable electron shells can form

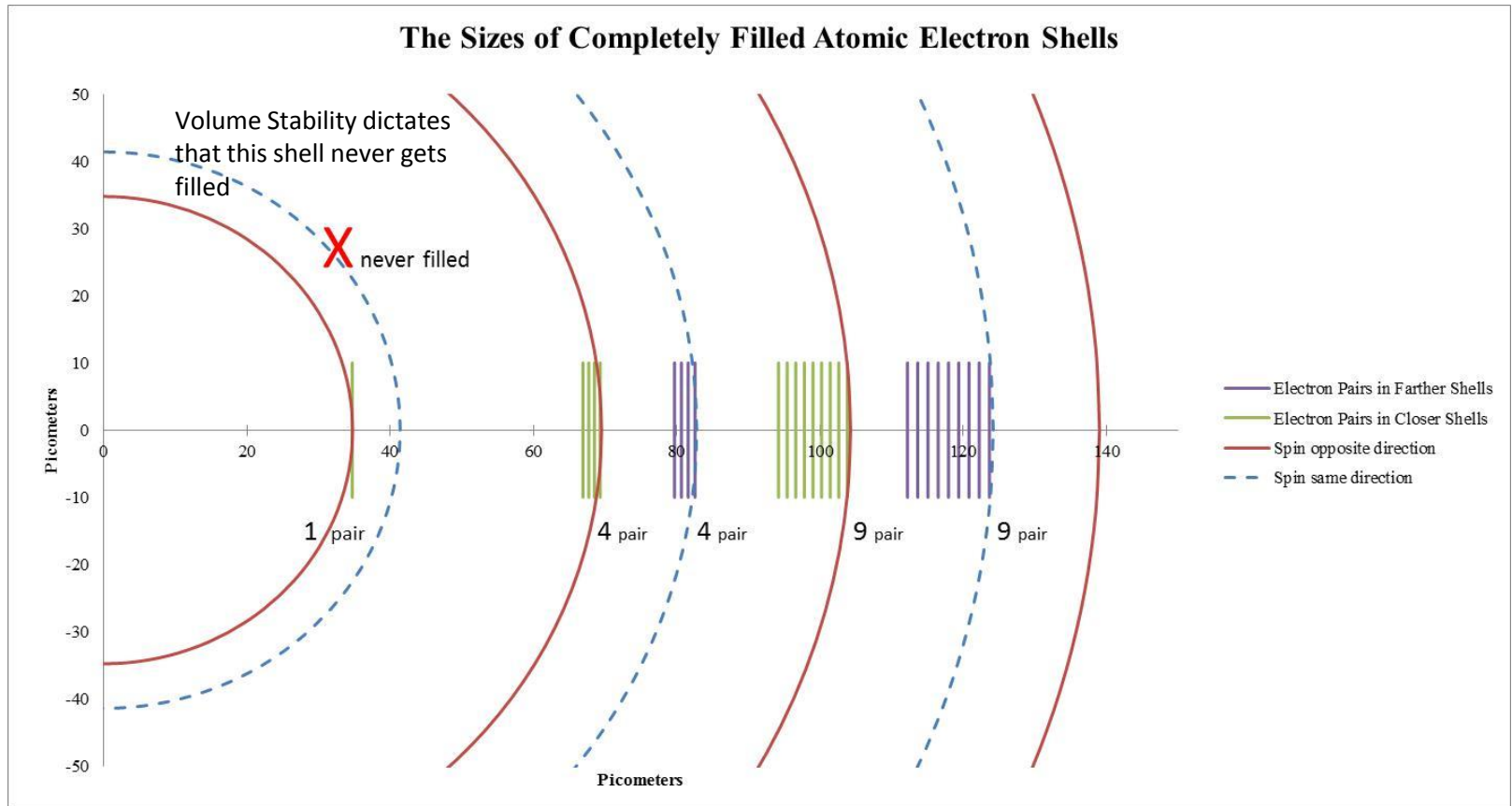

I had a potential problem, If my electrons are spheres then.... **What the Heck are these?**

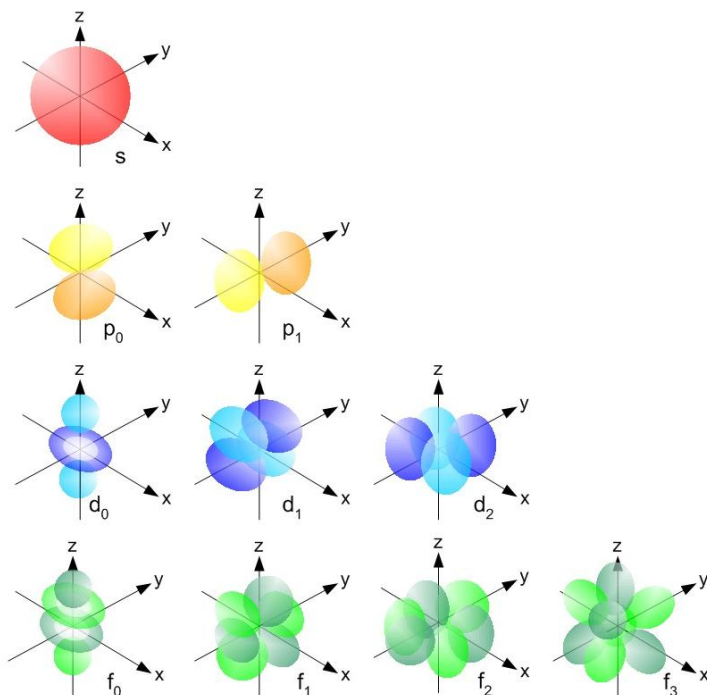

Calculated Electron “Shells” (Probability Distributions)

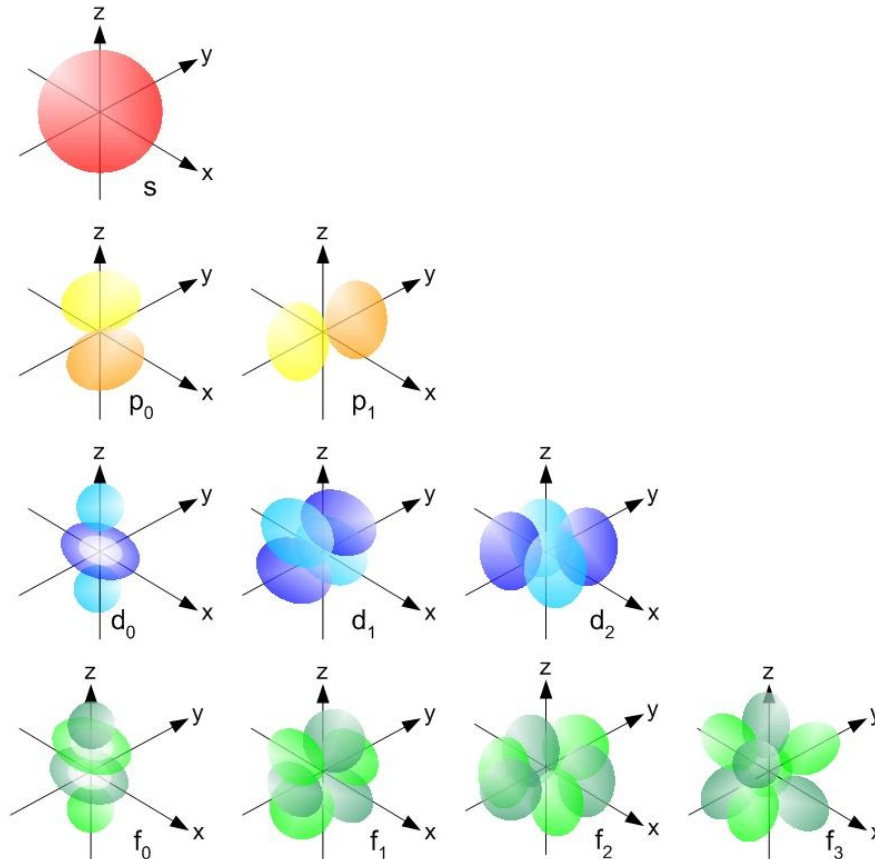

The answer came from an unexpected source.
Standing sound waves within the interior
spherical cavity of the basketball.



Vibration Modes, Basketball

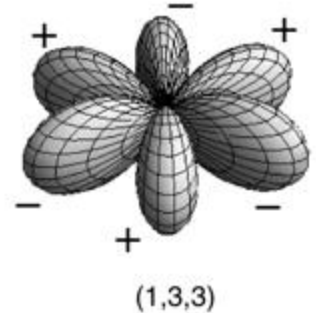
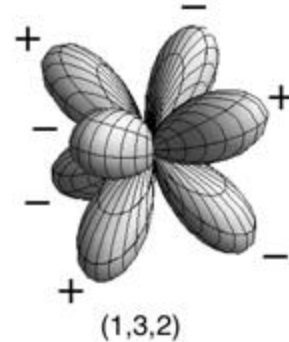
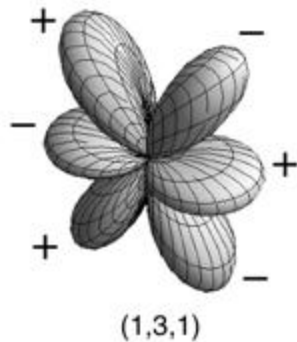
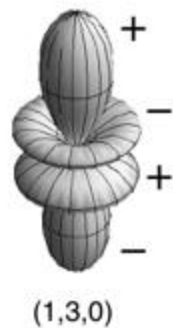
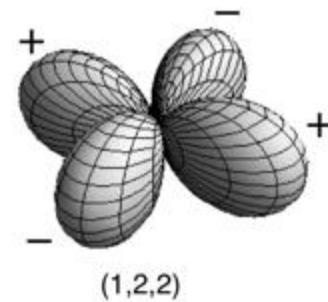
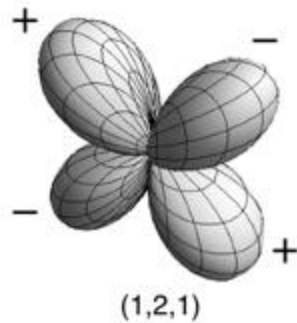
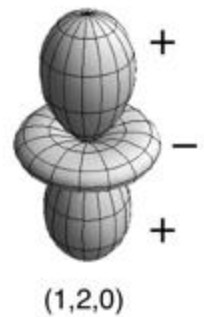
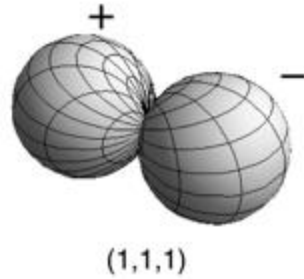
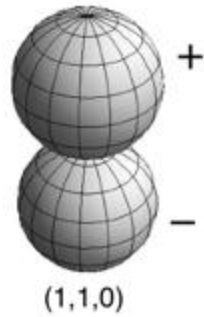

"Reproduced with permission from [American Journal of Physics "Basketballs as spherical acoustic cavities" Vol. 78 No. 6 June 2010 by Daniel Russell]. Copyright [2010], American Association of Physics Teachers." DOI: 10.1119/1.3290176

Vibration Modes of standing sound waves within the interior of the spherical cavity of the basketball vs. Spherical Electron Shells

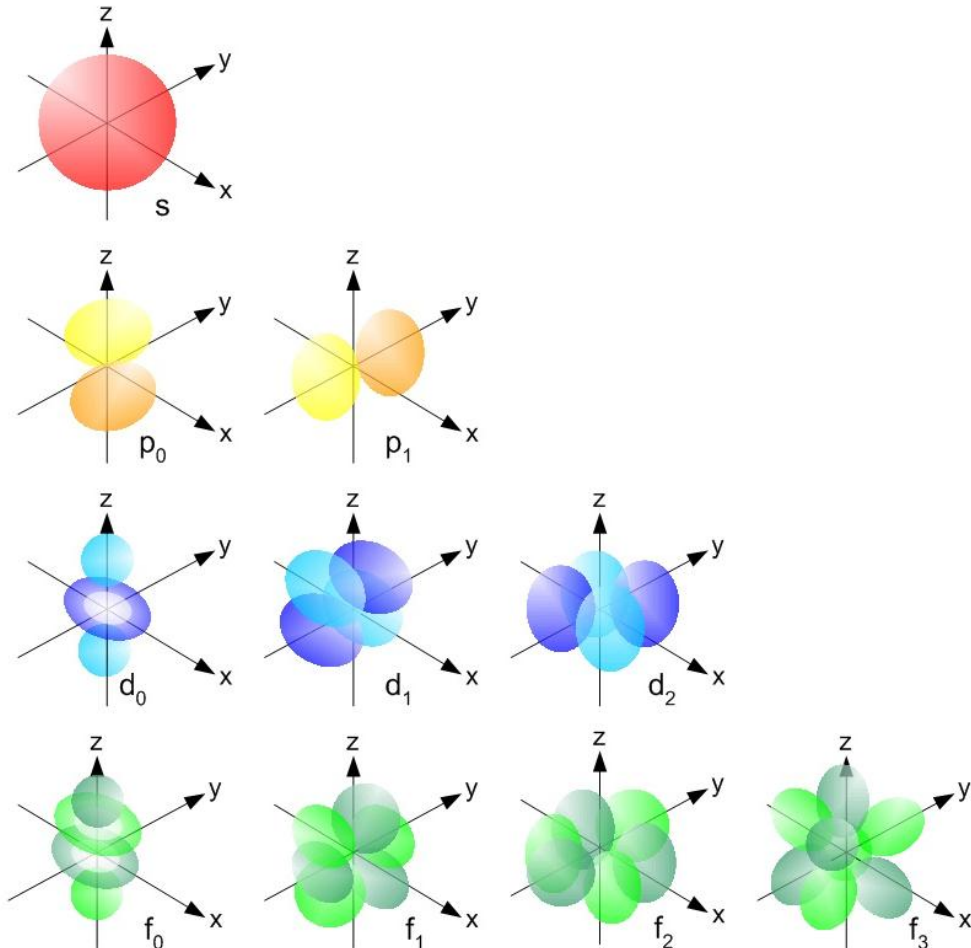
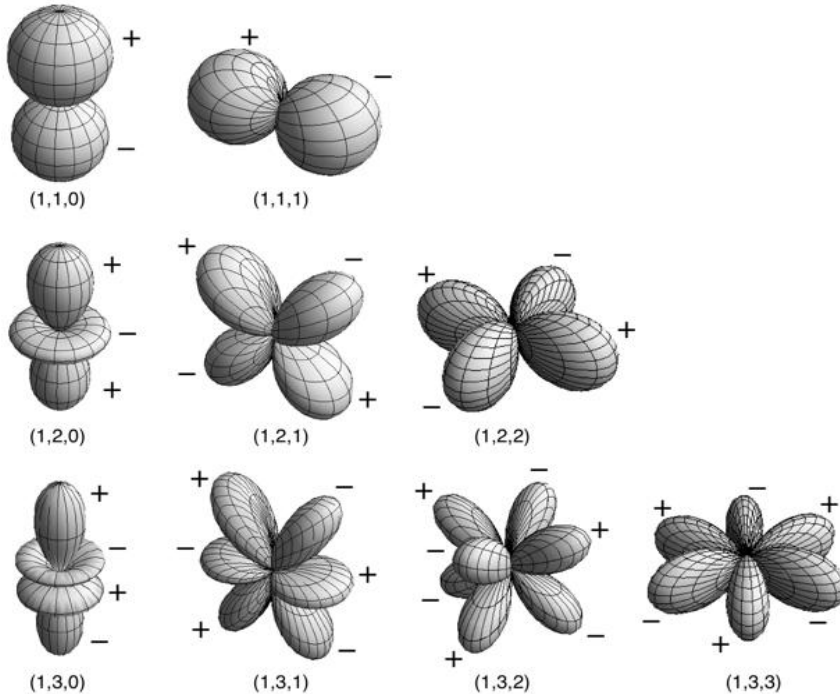

"Reproduced with permission from [American Journal of Physics "Basketballs as spherical acoustic cavities" Vol. 78 No. 6 June 2010 by Daniel Russell]. Copyright [2010], American Association of Physics Teachers." DOI: 10.1119/1.3290176

<http://creativecommons.org/licenses/by-sa/3.0/legalcode>

<http://chemistry.stackexchange.com/questions/8598/maximum-number-of-electrons-each-shell>

New Theory Predicts the Sizes of all of the Atoms

(Using new formula for resonant frequency)

Predicted vs. Measured Atomic Radii Based on new Theory of Resonant Electromagnetic Spheres

—●— predict ◆ empirical † ▲ Covalent (single bond) ■ Single Covalent

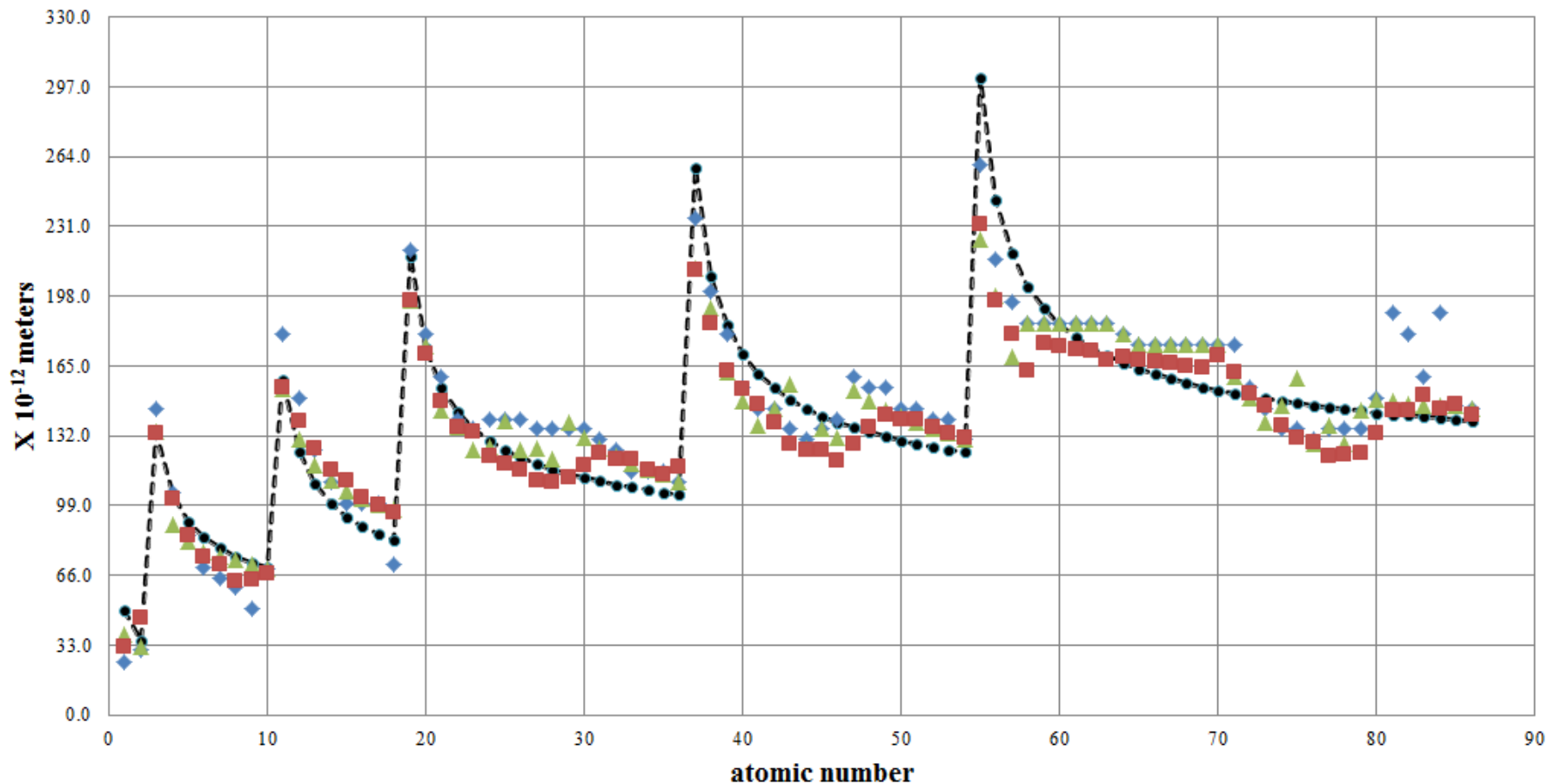

Gravity and Unification of the Four Forces

Gravity, Electrostatic, Nuclear Weak,
and Nuclear Strong

Proton Density Profile (η)

Linear Approximation

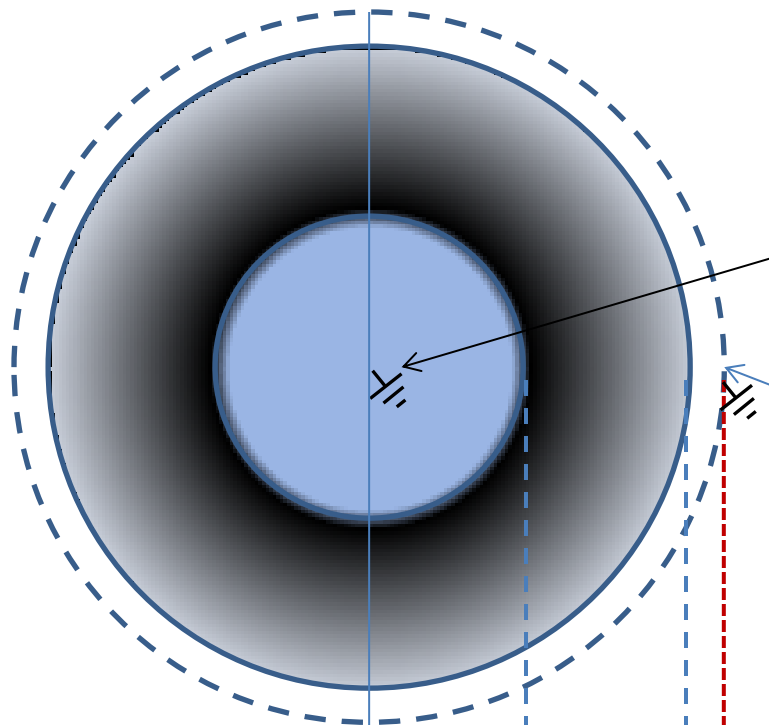

Virtual short circuit
At particle center

Next possible location of a
resonant short circuit

Different excess densities
determine the strengths of the
four forces

Peak Density $\eta = 1+1$

Non-Spinning Density just outside of the
resonant particle = 9.85% of the peak Density

$$\eta = 1 + \frac{2 \cdot (\pi/3 - 1)}{(2 - \pi/3)} = 1 + 9.9\%$$

$\eta = 1$

$$\leftarrow \frac{3}{\pi} \cdot \frac{\lambda}{2} \rightarrow$$

$$\leftarrow \frac{\lambda}{2} \rightarrow$$

What is Gravity?

The gravitational force

$$F_{\text{gravity}} = G (m_1 \cdot m_2) \div r^2 \quad \text{Where } G = 6.67 \times 10^{-11} \text{ (Newton} \cdot \text{meter}^2 \div \text{kilogram}^2)$$

The electrostatic force

$$F_{\text{electrostatic}} = K_e (q_1 \cdot q_2) \div r^2 \quad \text{Where } K_e = 9 \times 10^9 \text{ (Newton} \cdot \text{meter}^2 \div \text{coulomb}^2)$$

For two identical charged particles the ratio of the two forces

$$F_{\text{gravity}} / F_{\text{electrostatic}} = (G/K_e) \cdot m^2 \div q^2$$

For two particles that are identical, assign the square root of this ratio to each.

$$(F_{\text{gravity}} / F_{\text{electrostatic}})^{1/2} = (G/K_e)^{1/2} \cdot m \div q$$

Using the energy equations, solve for charge q.

$$e = m \cdot C^2 = V \cdot Q \quad \text{therefore } q = Q = m \cdot C^2 \div V$$

Substitute for q

$$(F_{\text{gravity}} / F_{\text{electrostatic}})^{1/2} = [(G/K_e)^{1/2} \cdot m \div m] \cdot V \div C^2$$

The bracketed term looks like a constant fractional mass with a value of

$$(G/K_e)^{1/2} = 8.609 \times 10^{-11}$$

Using the mass-density relationship, tenth root of $(G/K_e)^{1/2} = (8.609 \times 10^{-11})^{.1} = .0985 = 9.85\%$

Gravity is the excess density contained outside of a resonant particle!

Visible and Dark Matter have nearly the same excess density outside of the spinning resonance when compared to the peak
9.85% vs. 9.66%

The amount of non-spinning excess density outside of the Dark resonance increases by η^2 and so does the peak

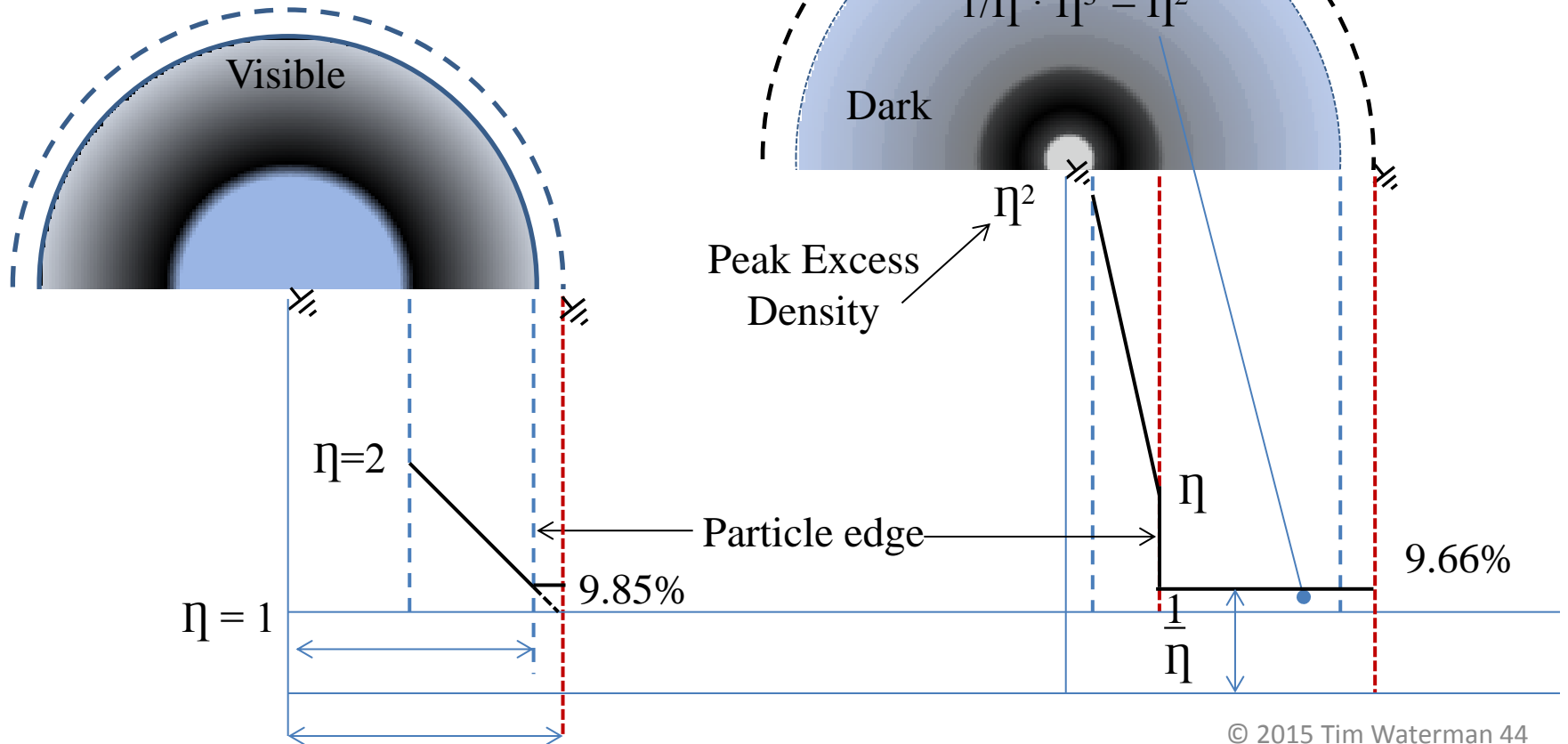

The Proton (Nuclear Strong Force)

2 Tiered
Resonant
Particle

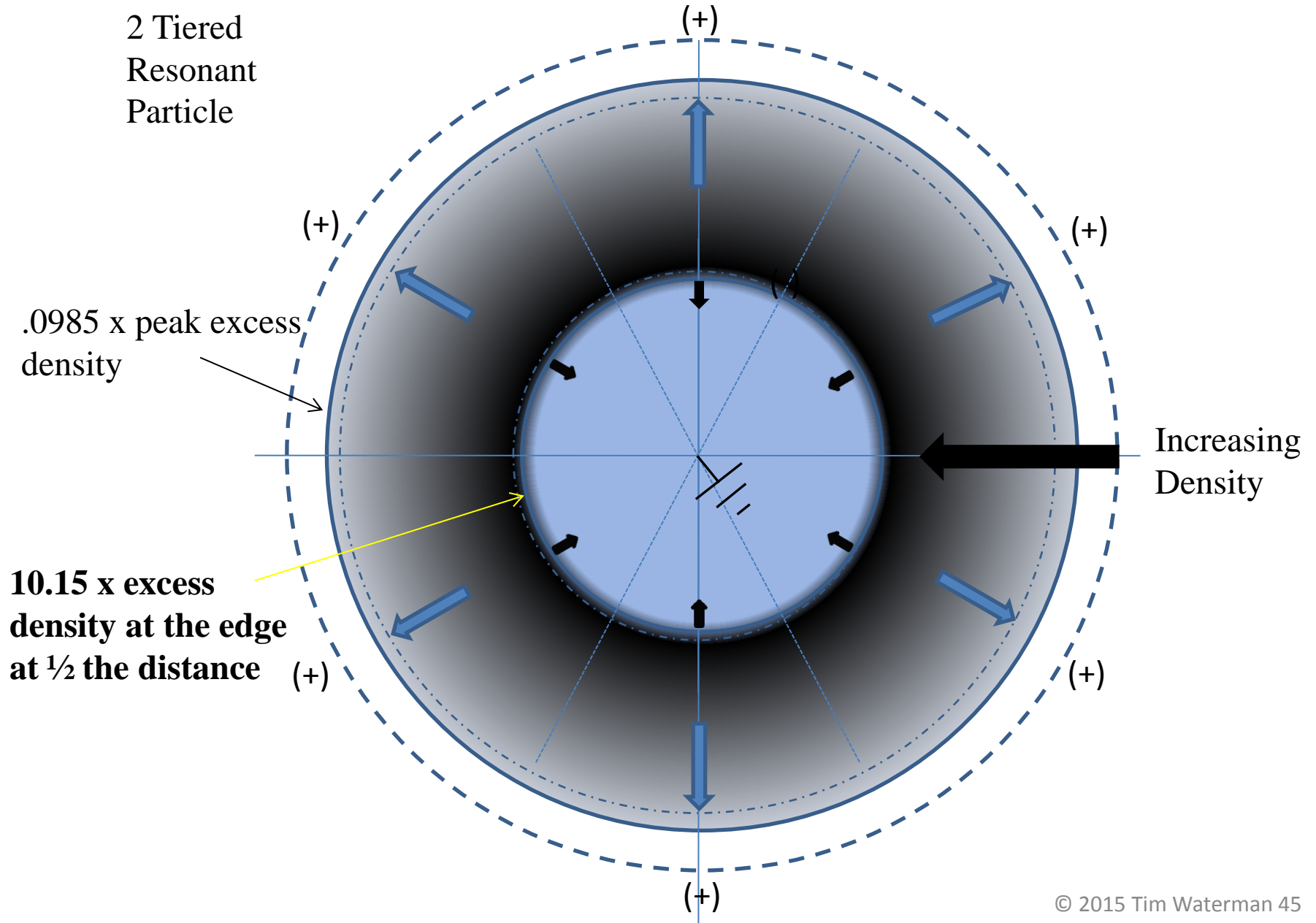

The Proton (Nuclear Strong Force)

$$F_{\text{electrostatic}} \text{ (electrostatic)} = K_e (q_1 \cdot q_2) \div r^2$$

$$F_{\text{electrostatic}} \text{ (strong)} = K_e (10.15 \cdot q_1 \cdot 10.15 \cdot q_2) \div (r/2)^2$$

$$F_{\text{electrostatic}} \text{ (strong)} = \underline{\mathbf{412.3}} \cdot F_{\text{electrostatic}} \text{ (electrostatic)}$$

Strong Force is 10.15 times the density at 1/2 the spacing
Compared to the Electrostatic Force

Electrostatic Charges explain the Weak Nuclear Force

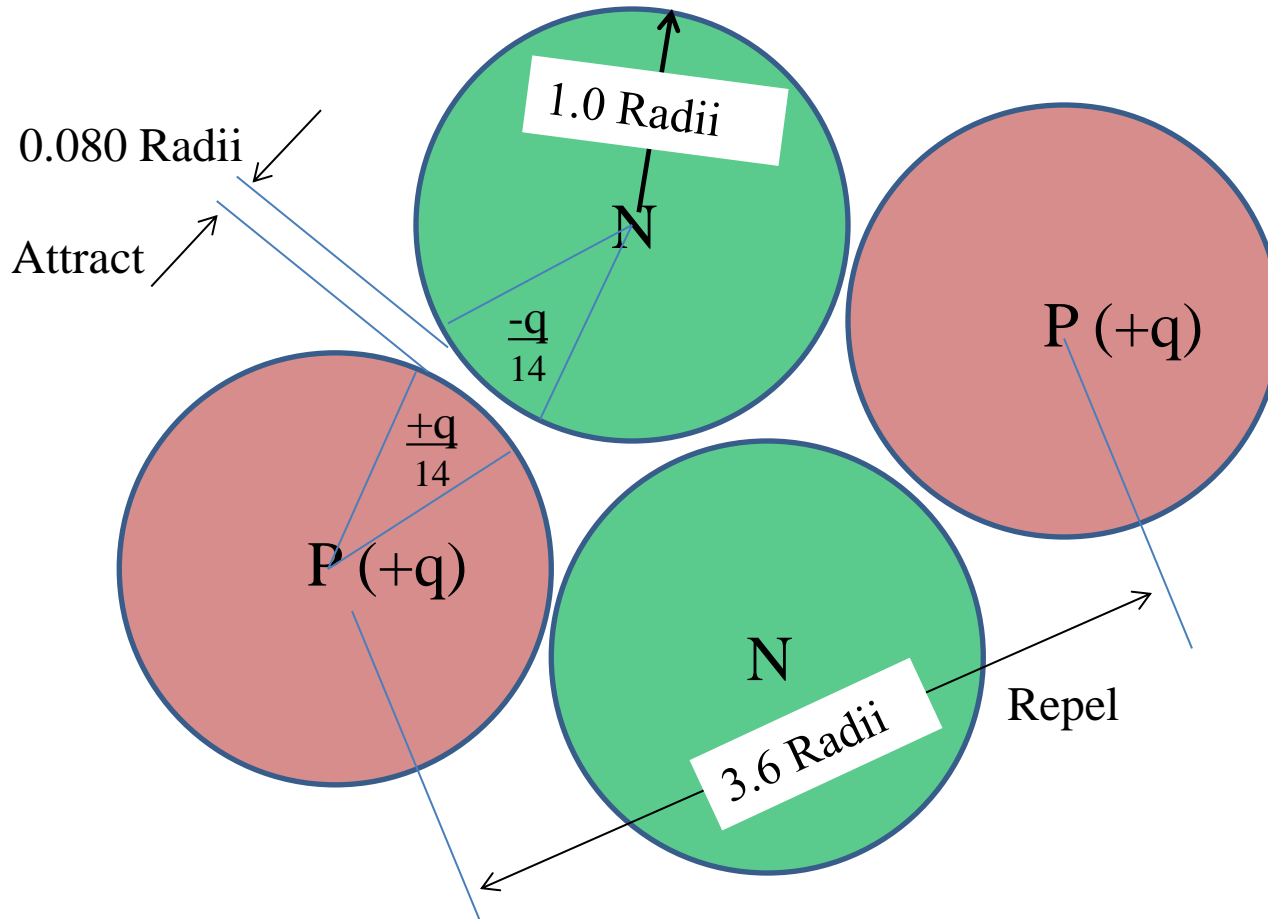

Attractive and Repulsive forces are balanced at these spacings

Comparison of Published vs. Calculated Strengths using this new Theory

| | Windows2 universe.or g | Georgia State University | SciencePark.e tacude.com | New World Encyclopedia | New Theory Calculated Strengths |
|-----------------|------------------------------|--------------------------------|-----------------------------|---------------------------|--|
| Strong | 1 | 1 | 1 | 1 | 1 |
| Electromagnetic | 0.007 | 0.007 | 0.010 | 0.010 | 0.002 |
| Weak | 1.00E-09 | 1.00E-06 | 1.00E-07 | 1.00E-13 | 6.11E-09 |
| Gravity | 1.00E-38 | 1.00E-39 | 1.00E-38 | 1.00E-38 | 1.93E-39 |

Galaxies

Compressing Space Smaller and Smaller (not to scale)

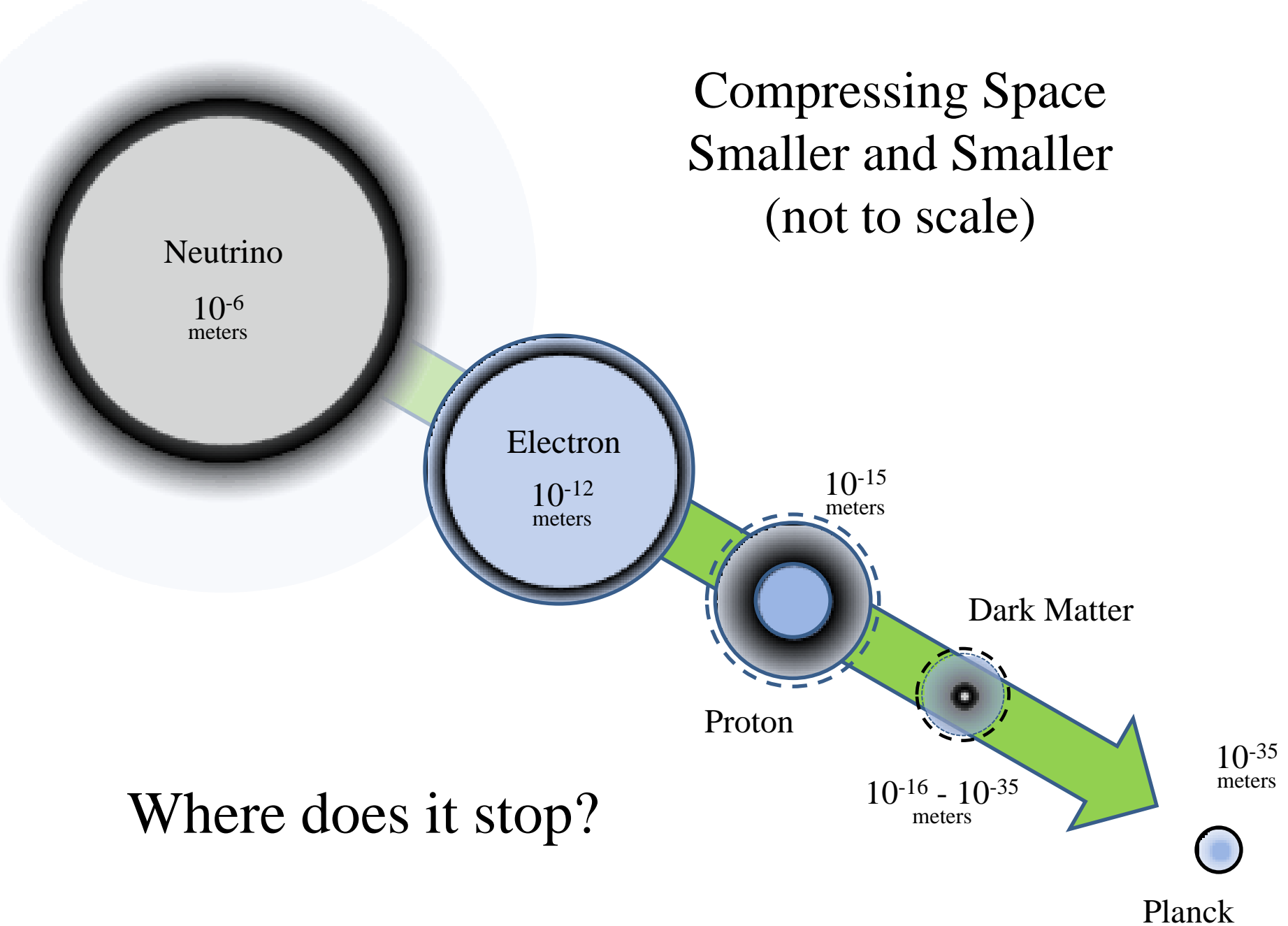

Where does it stop?

If there was a Planck size “Bounce Mode” Particle (not predicted, but)

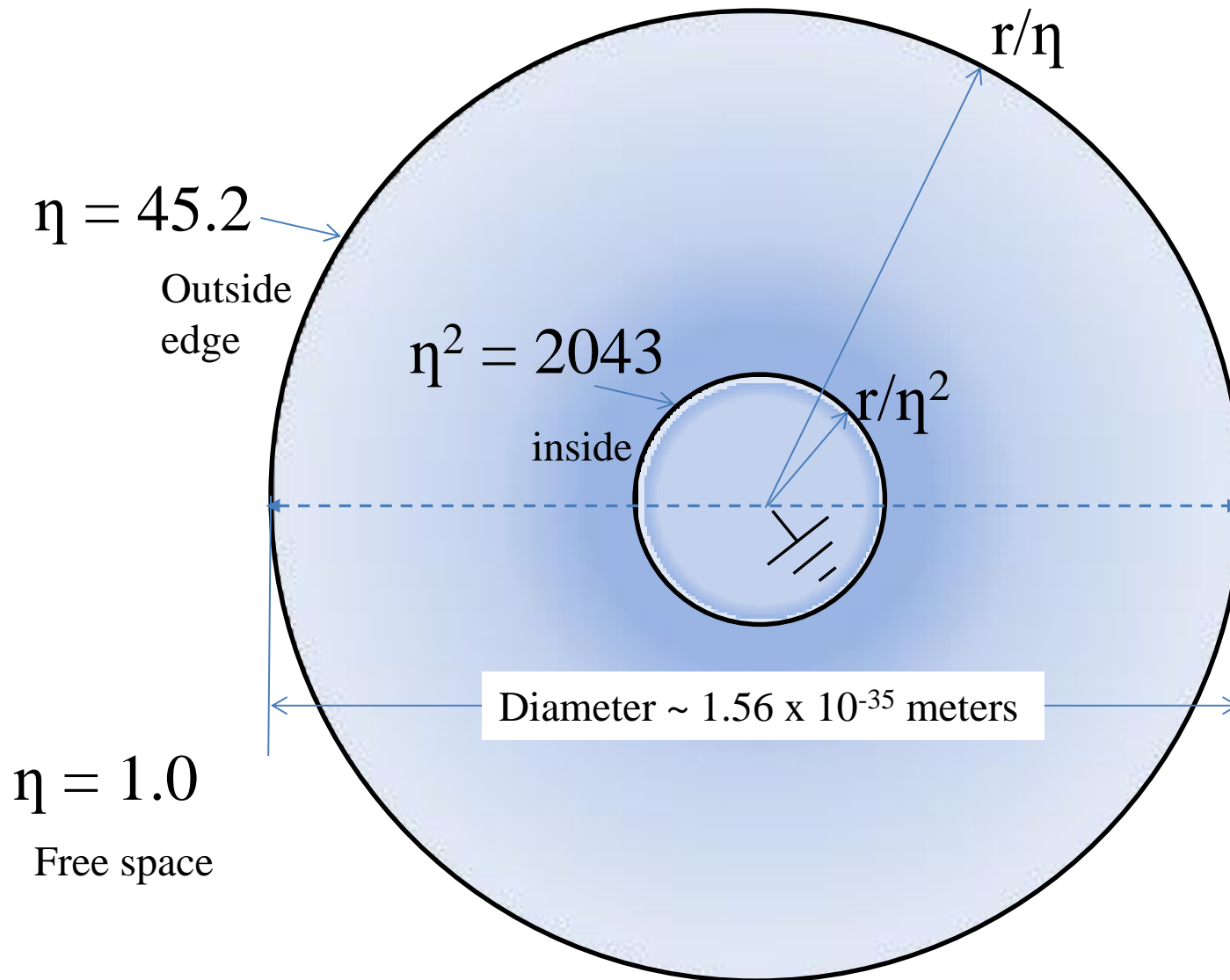

For Bounce Modes the maximum density η^2 Occurs at the minimum radius of r/η^2

Uniform Density / Maximum Compression

If the Planck length is the minimum length what pressure and density does it take to completely fill the Planck volume uniformly?

At that maximum uniform density, how much mass-energy is contained inside?

Planck size “Uniform Sphere”

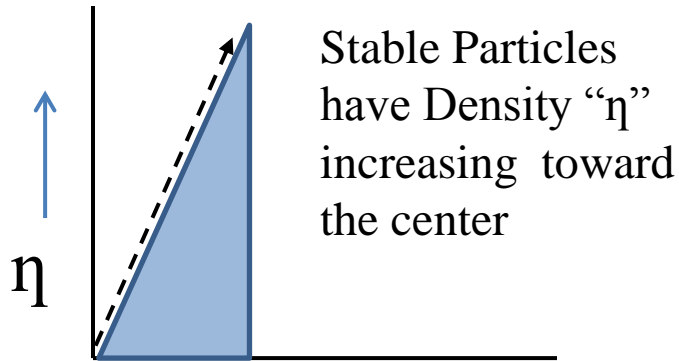

Toward Center →

Volts x 2

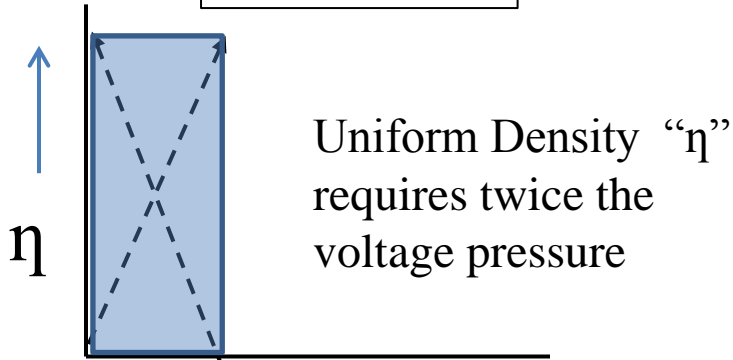

Toward Center →

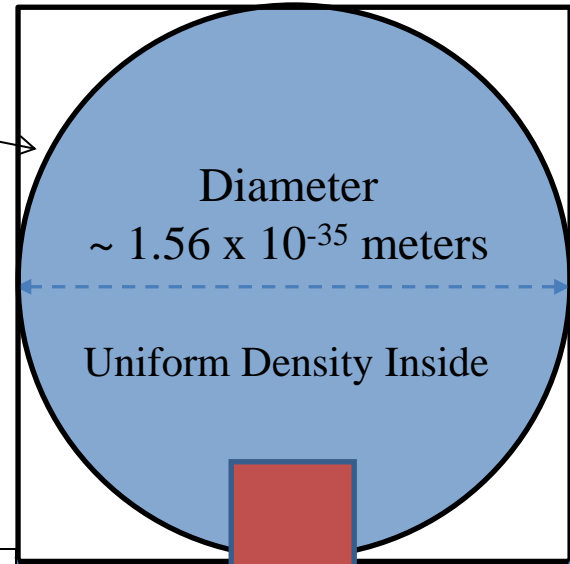

Volts x
1.235

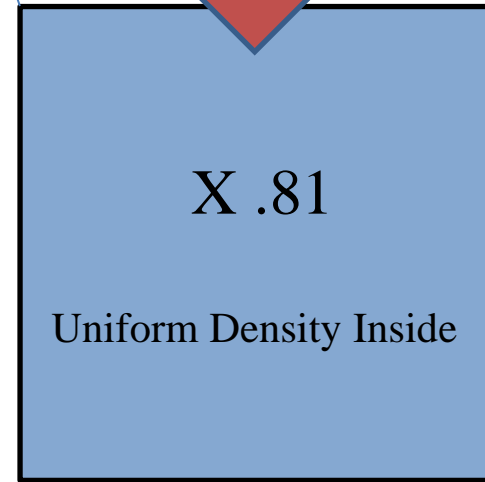

Width
~ 1.264 x 10⁻³⁵ meters

Uniform Density / Maximum Compression Total Mass contained in a Planck Volume

$$\eta_{\text{edge}} = 45.2 \cdot 1.0718 \cdot 1.0213 = 49.48$$

Therefore the maximum density for uniform filling

$$\eta_{\text{max}} = \eta_{\text{edge}}^2 = 2448$$

$$f_{\text{max}} = f_0 \cdot \eta_{\text{max}}^{10} = 9.55 \times 10^{53} \text{ Hz}$$

$$E_{f_{\text{max}}} = m_{f_{\text{max}}} \cdot C^2 = h \cdot f_{\text{max}} \quad \text{where } C = C_0 \div \eta_{\text{max}}$$

Mass for one volume of f_{max} .

$$m_{f_{\text{max}}} = [\eta_{\text{max}}^2 \cdot h \cdot f_{\text{max}} \div C_0^2]$$

$$N_{\text{volumes}} = (f_{\text{max}}/f_{\text{Planck}})^3 = 1.4 \times 10^{32} \text{ volumes}$$

Total Mass in the volume of one Planck cube.

$$m_{\text{total}} = N_{\text{volumes}} \cdot m_{f_{\text{max}}}$$

$$m_{\text{total}} = 5.899 \times 10^{42} \text{ kg}$$

(This is the current average estimate of the total Mass in a Galaxy..... Visible + Dark Matter +Dark Energy!)

Neutrinos and Super-Massive Black Holes

Where are the Compressive waves?

There must have been some compressive waves generated during the Big Bang

Unlike TEM waves (transverse electromagnetic), compressive waves travel in the direction of pressure (like sound)

The expanding waves stop when the bubble wall thickness hits the Planck length

The radius of the bubble is related to the amount of compressive wave energy contained inside

Two structures....the Neutrino and Super-massive Black Holes are compressive wave structures.

Increased Density of 1.0 Q when going from the Electron size to the Neutrino

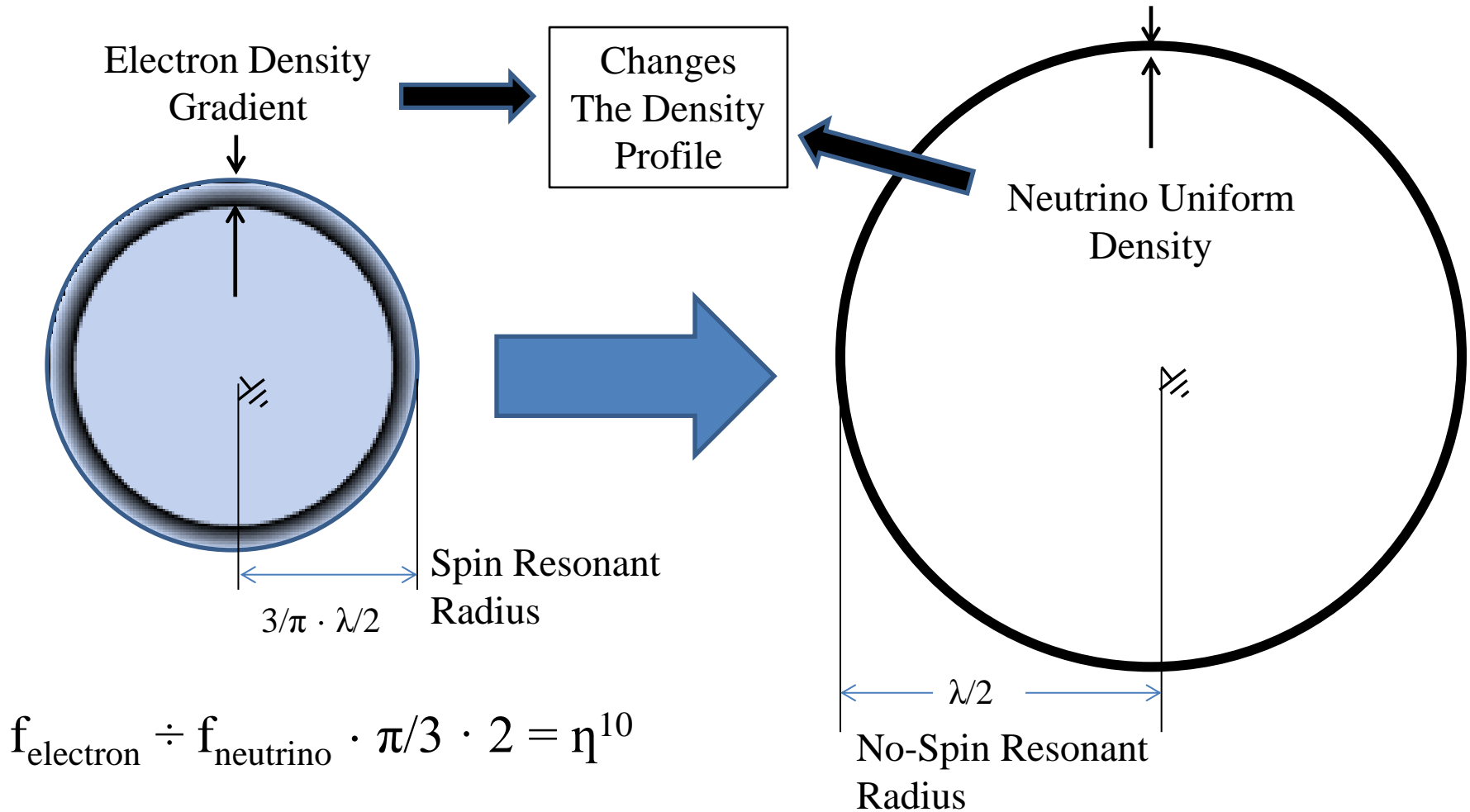

$$f_{\text{electron}} \div f_{\text{neutrino}} \cdot \pi/3 \cdot 2 = \eta^{10}$$

$$\eta_{\text{peak}} = 4.49/2 = 2.25$$

Density Profile of a Super Massive Black Hole makes it's Gravity Stronger Relative to its Mass

[1/2 of the Mass is outside of the particle]

Exterior Density is 9.47 times greater than normal resonant particles.
Therefore its effective mass (strength of Gravity) is $(9.47)^{10} = 5.82 \times 10^9$ greater than normal visible matter.

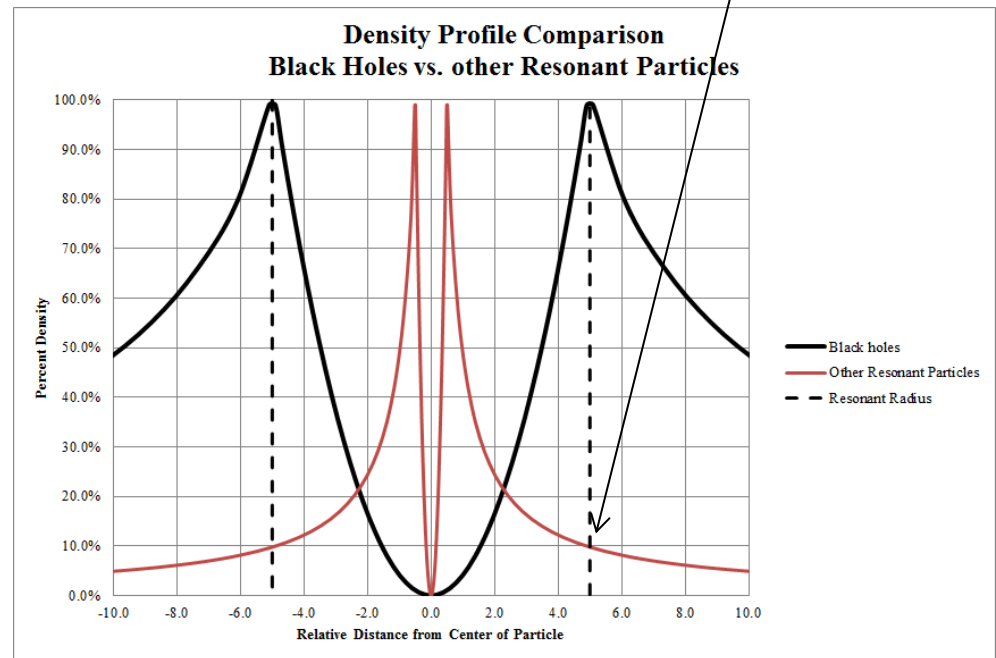

Black Hole
Physical
Diameter = λ

The Total Universe and a Plausible Aether

Background Microwave frequency along with Planck-Galaxy expansion allows a prediction of the size of the total Universe

Expansion of the universe = [average galaxy radius ÷ Planck radius]

$$2.0 \times 10^{57} = 1.54 \times 10^{22} \text{ meters} \div 0.75 \times 10^{-35} \text{ meters}$$

Frequency_{start of universe} = Microwave Background Frequency · Expansion

$$3.2 \times 10^{68} \text{ Hz} = 1.6 \times 10^{11} \text{ Hz} \cdot 2.0 \times 10^{57}$$

This starting frequency is 3.35×10^{14} higher than the Galaxy frequency

$$(f_{\max} = 9.55 \times 10^{53} \text{ Hz}).$$

The higher frequency indicates a structure with more energy.

I propose that the higher frequency correlates to the total number of galaxies. Current estimates for the visible universe

$$6.1 \times 10^{11} \text{ Galaxies}$$

The higher starting frequency would suggest that the total universe is

~549 times the visible universe

Planck Cubes fill up the “Total” Early Universe before the Big Bang

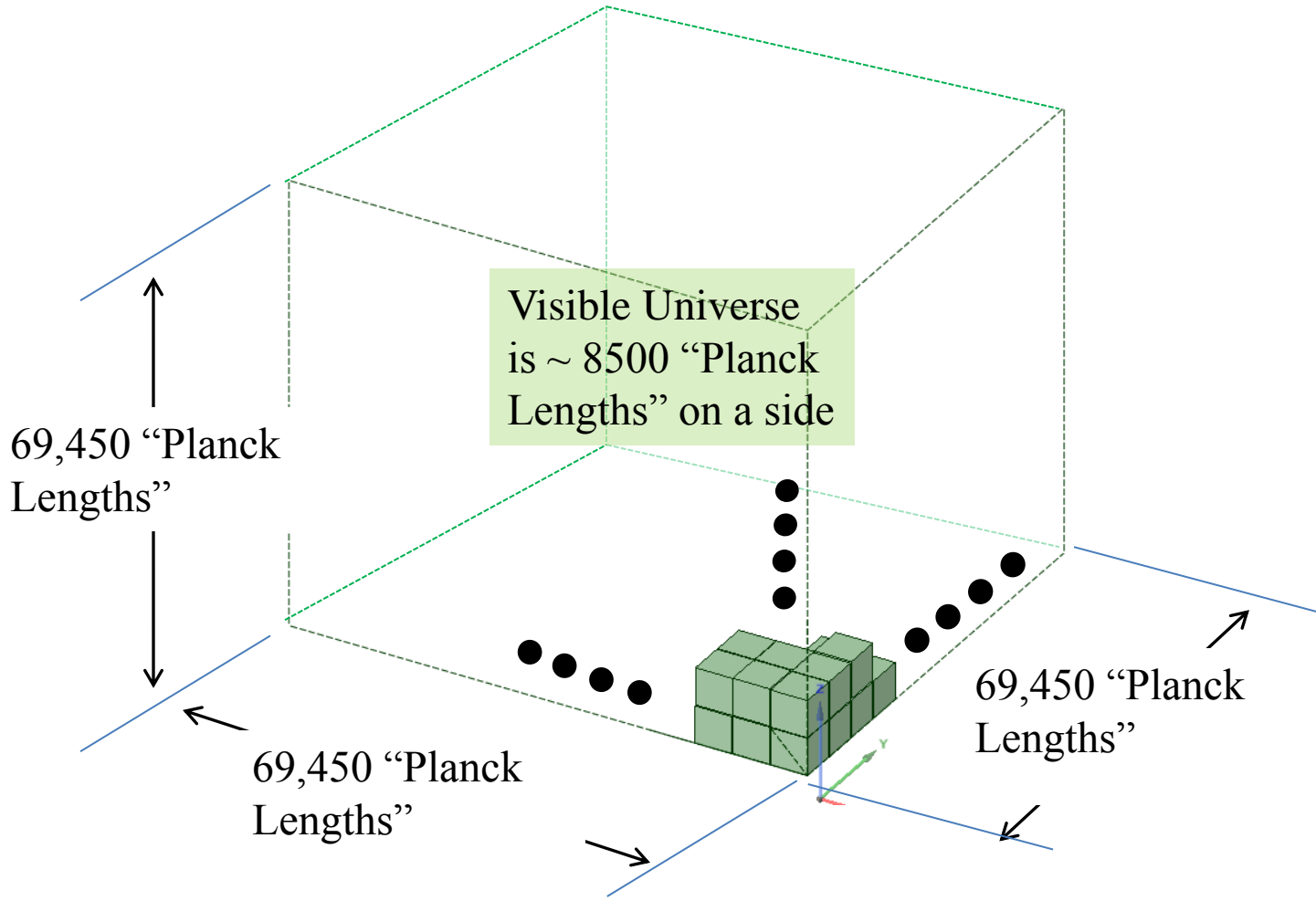

Imagining the Aether

- The material must be springy and compressible across a wide range of densities.
- The material appears to have a maximum compressibility (the early universe $\eta=2448$)
- The material has a maximum stretch (the speed of light being constant today $\eta=1.0$).
- Both of these values for stretch and compressibility seem to be connected to the “Planck Length” of approximately 10^{-35} meters.

Unimaginably thin wires arranged as orthogonal loops could sustain vibration (waves) and be able to fold in on themselves when compressed.

Because the wires have size, at the maximum point of compression, the unit cell will be completely filled and hit a maximum density ($\eta \sim 2448$).

Possible Aether “unit cell” (3 Orthogonal Springy Loops)

